

FR Guide de l'utilisateur
EN User guide
DE Bedienungsanleitung
NL Gebruiksaanwijzing
ES Guía del usuario
PT Guia del usuario
IT Manuale d'uso
DA Brugsvejledning
NO Bruksanvisning
SV Användarhandbok
FI Käyttöopas
TR Kullanım kılavuzu
EL Οδηγός χρήσης
PL Instrukcja obsługi
CS Návod k použití
SK Používateľská príručka
HU Használati útmutató

SL Navodila za uporabnika
RU Руководство пользователя
UK Посібник користувача
HR Upute za uporabu
RO Ghidul utilizatorului
ET Kasutusjuhend
LT Naudotojo vadovas
LV Lietošanas pamācība
BG Ръководство на потребителя
SR Uputstvo za upotrebu
BS Uputstvo za upotrebu
HK 用戶指南
MS Panduan pengguna
VI Hướng dẫn người sử dụng
FA راهنمای کاربر
AR دليل المستخدم
TH คู่มือผู้ใช้

#1

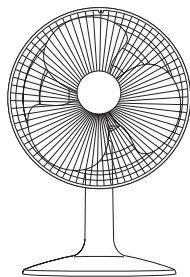

VU231xxx / VF231xxx

#2

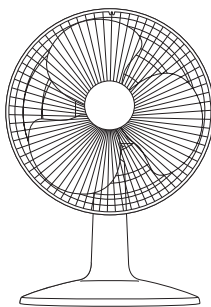

VU233xxx / VF233xxx

#3

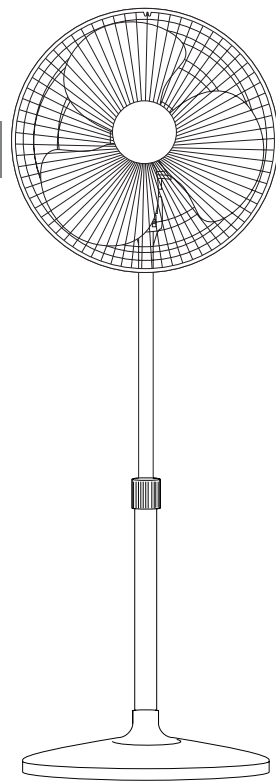

VU441xxx / VF441xxx

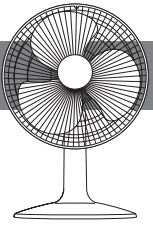

ESSENTIAL+

VU231xxx / VF231xxx

#1

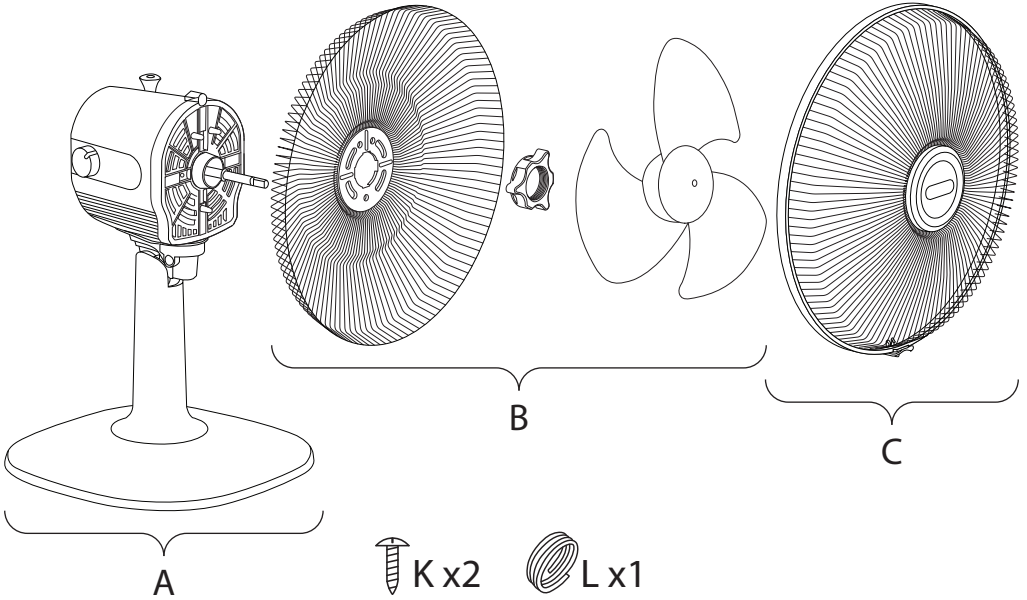

A

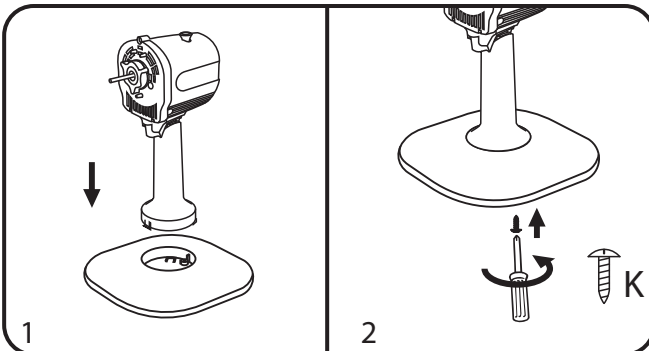



B

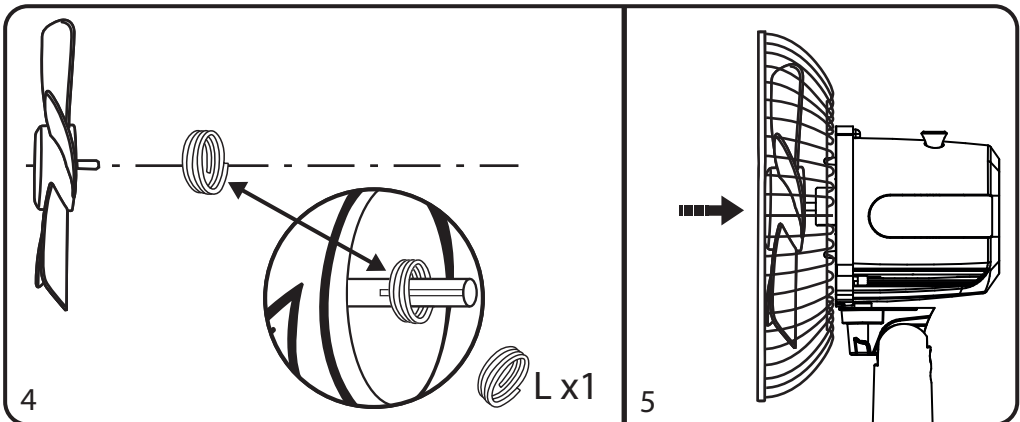
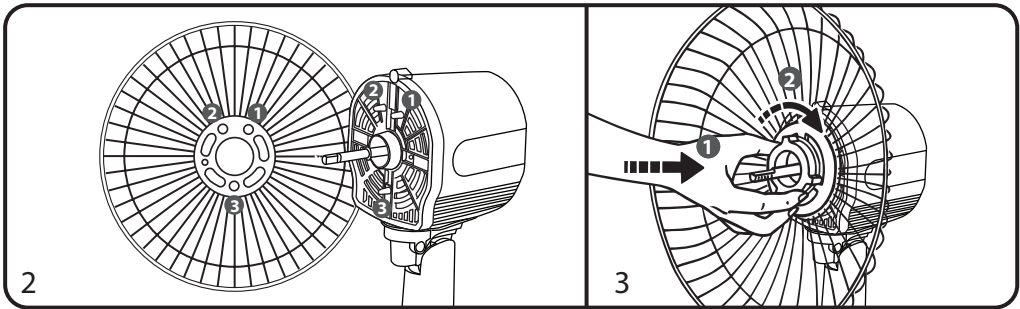
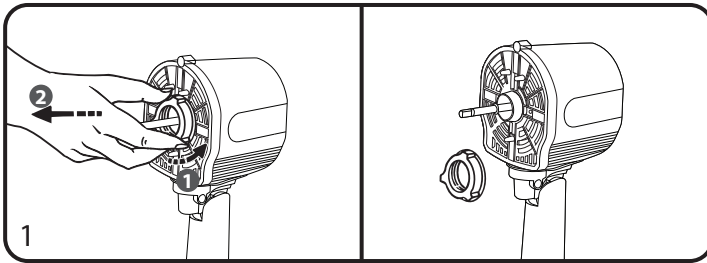

C

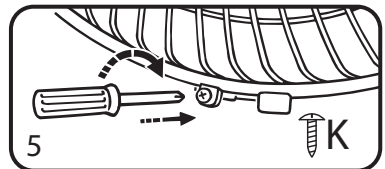
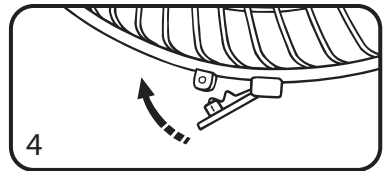
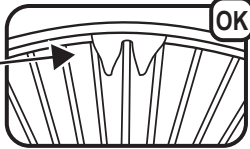
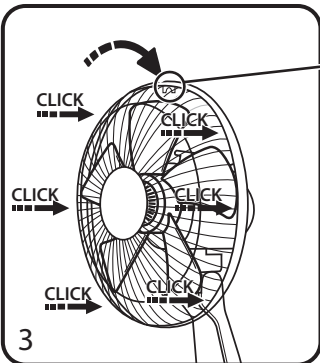
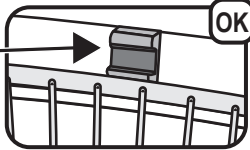
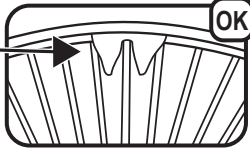
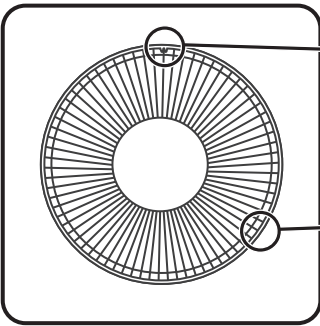
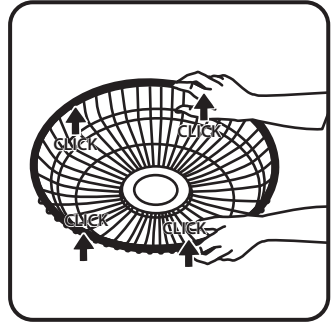
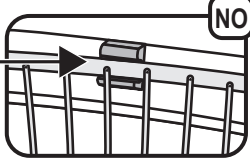
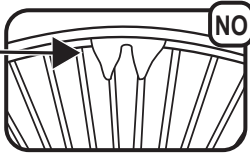
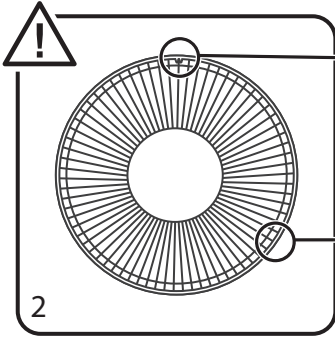
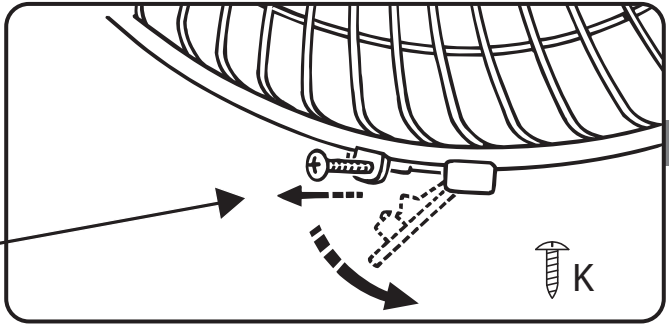
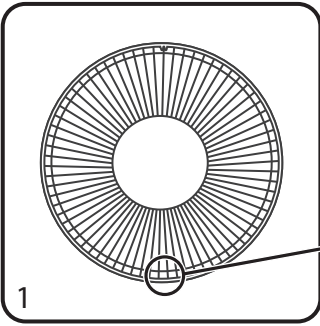

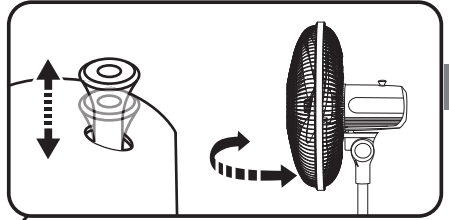
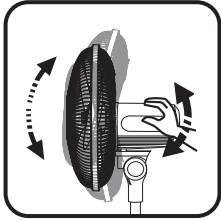
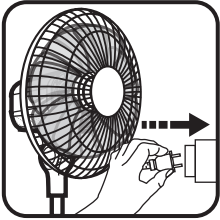

#1

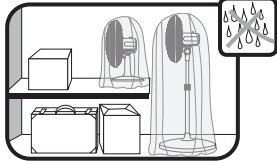
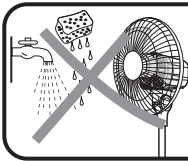
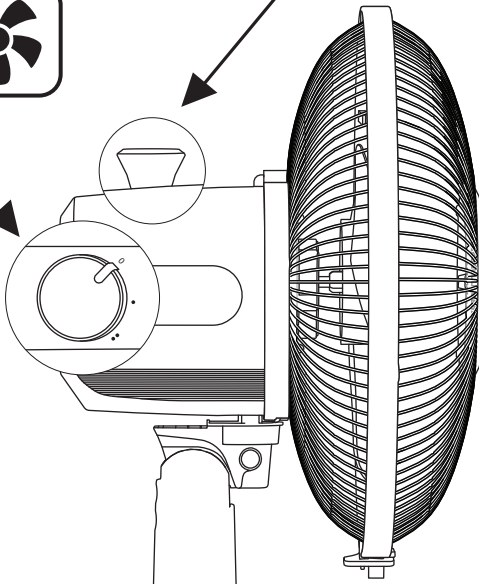

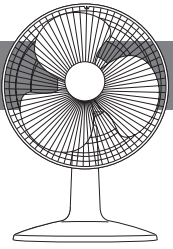

ESSENTIAL+

VU233xxx / VF233xxx

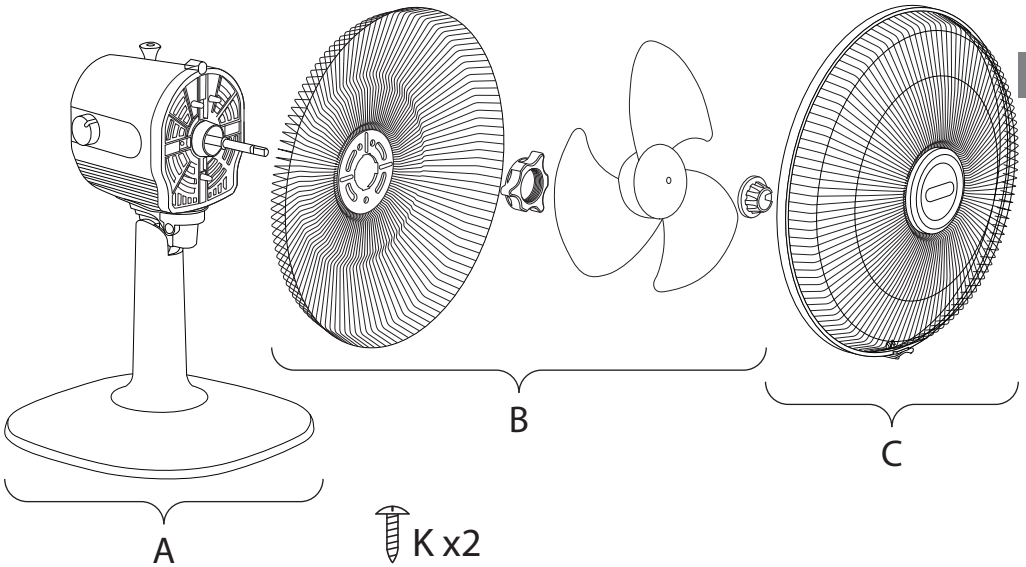

#2

A

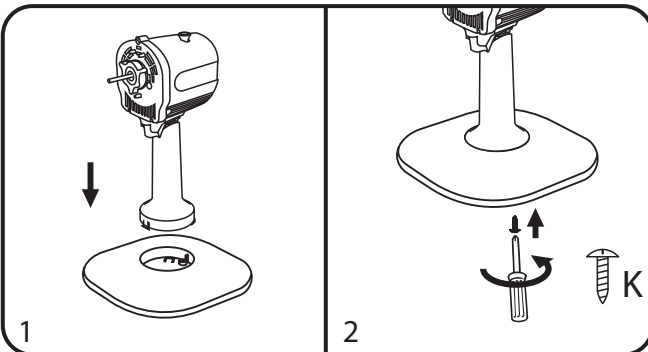



B

#2

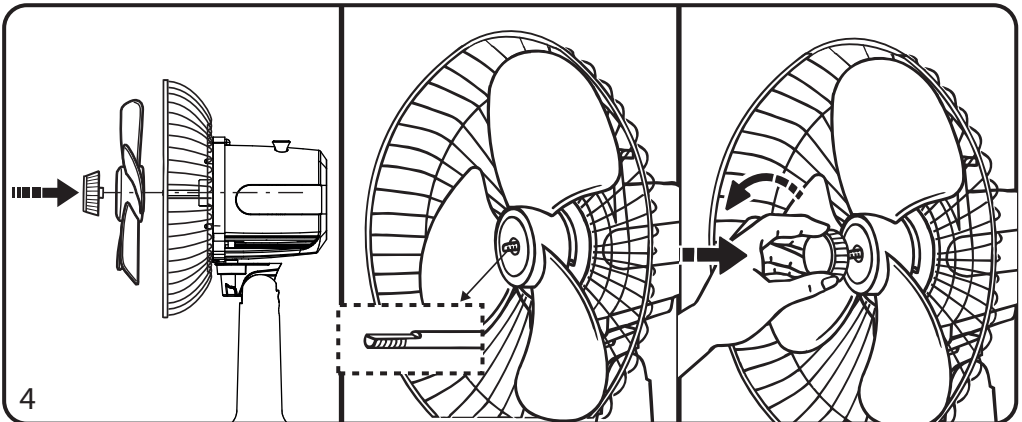
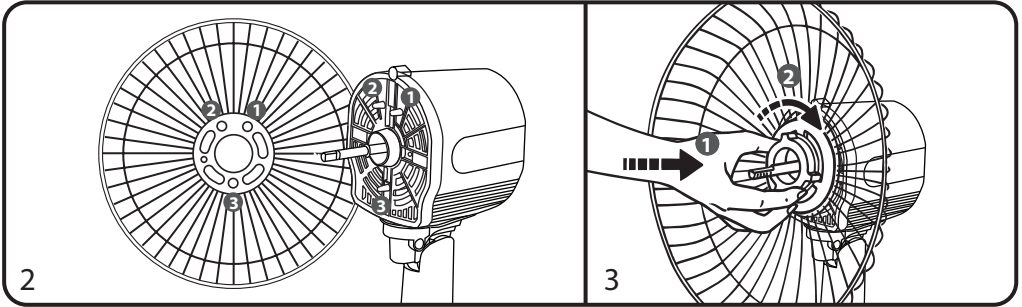
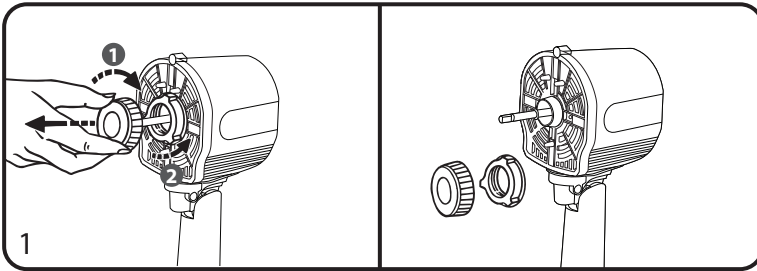

C

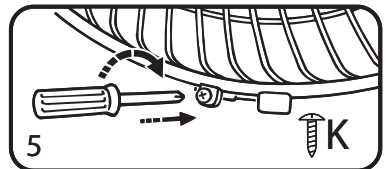
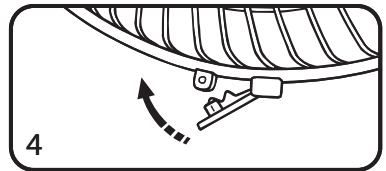
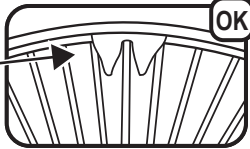
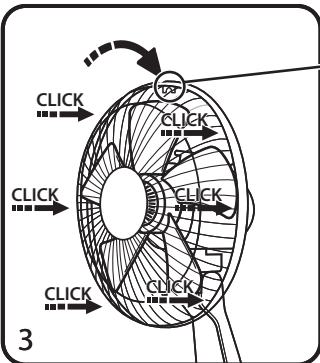
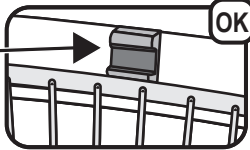
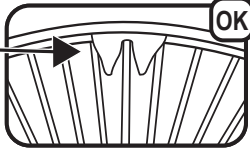
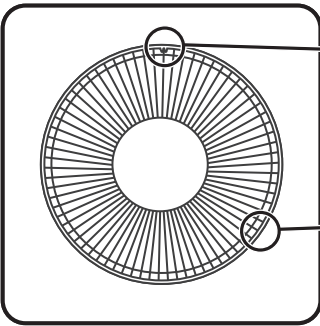
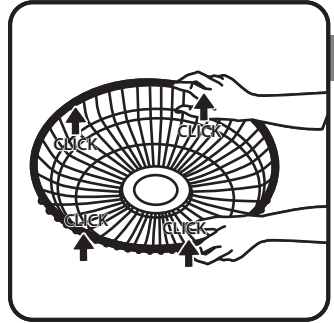
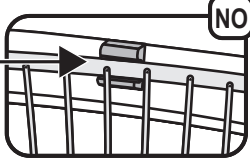
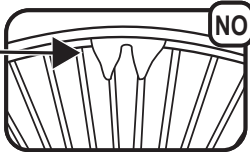
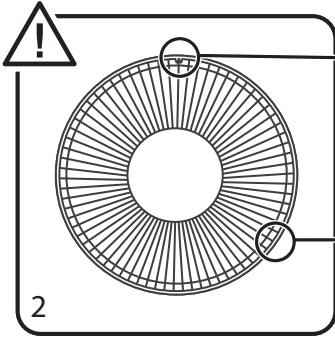
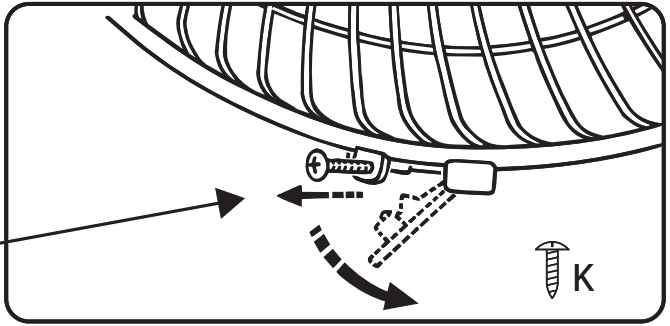
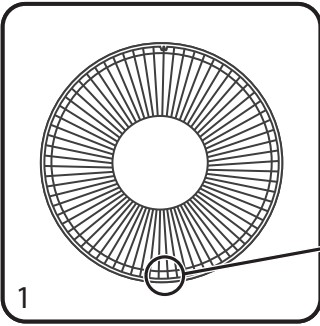

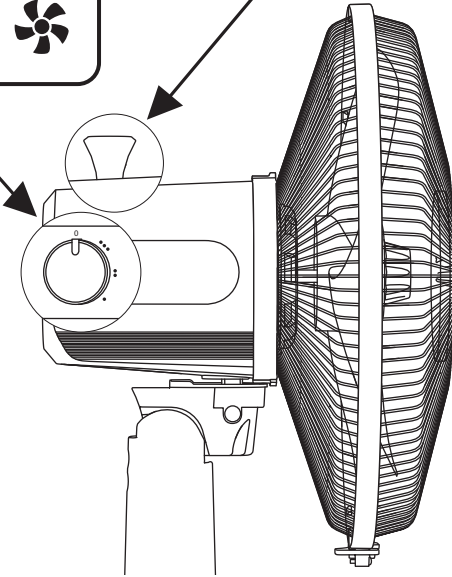
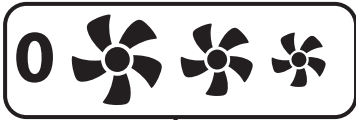
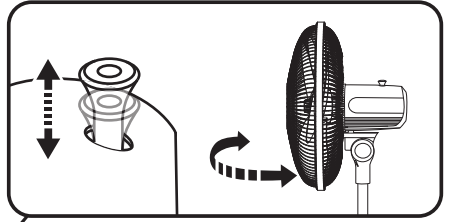
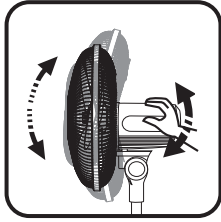
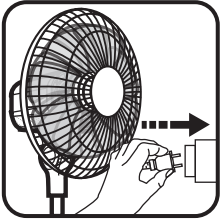

#2

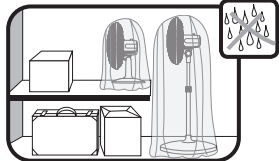
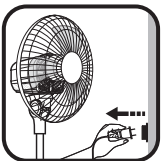
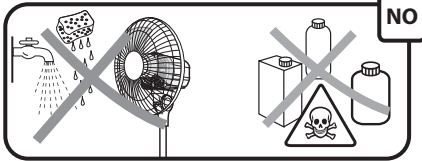
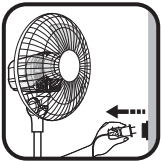

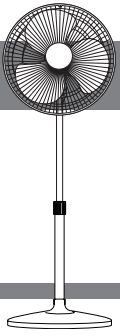

ESSENTIAL+

VU441xxx / VF441xxx

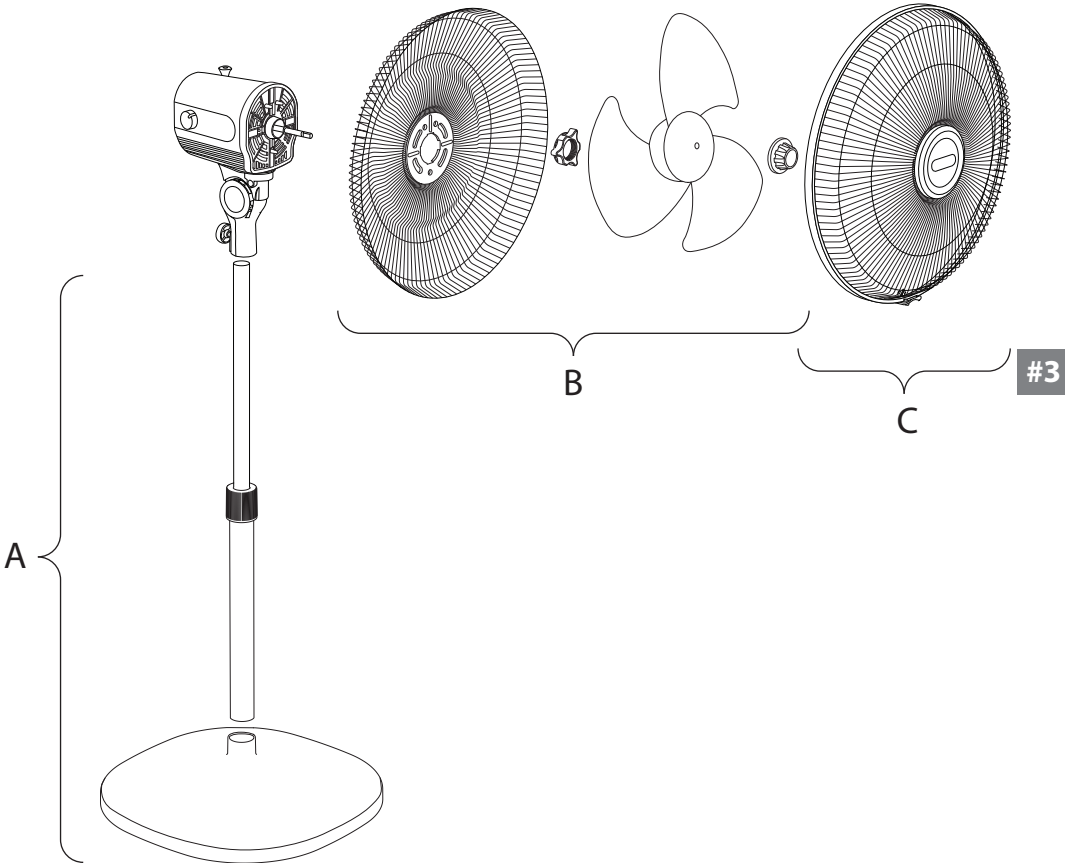

A

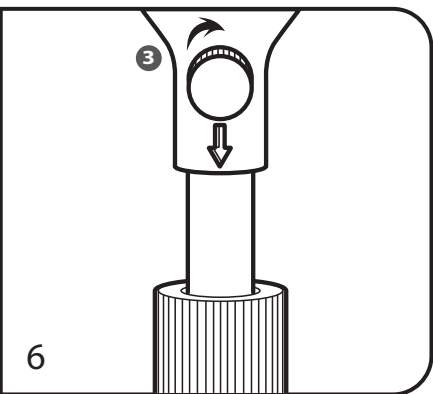
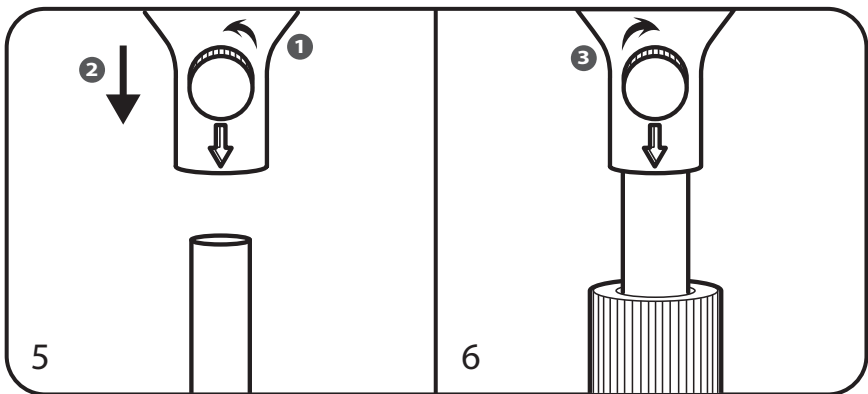
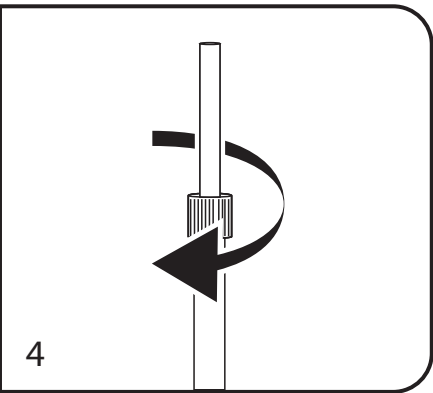
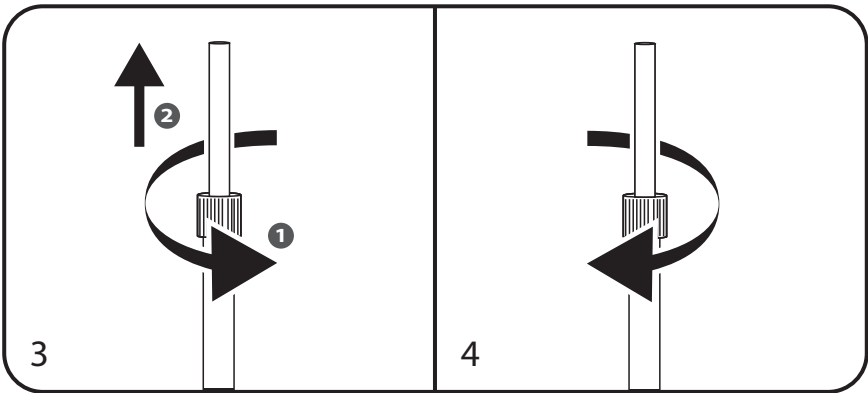
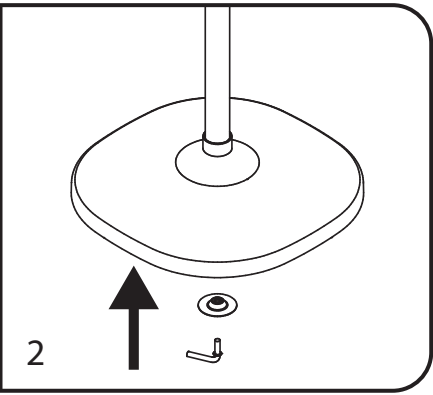
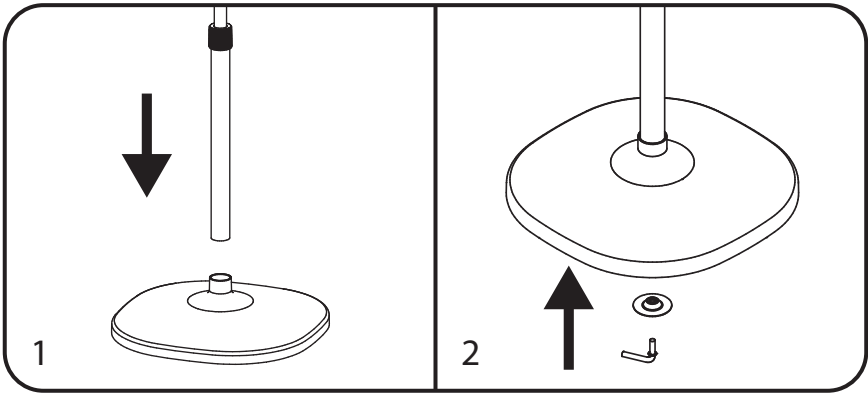

#3



B

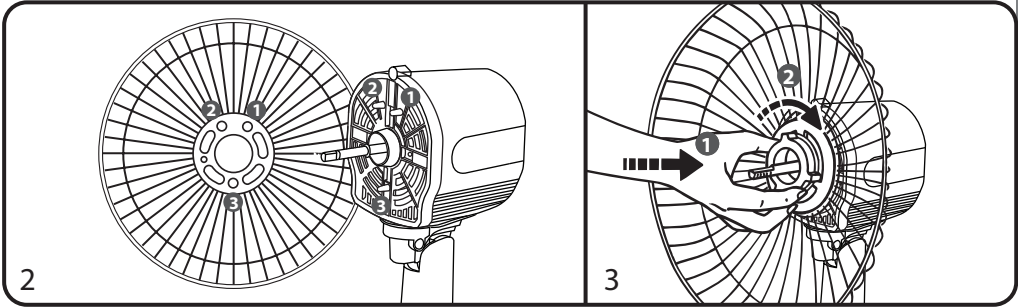
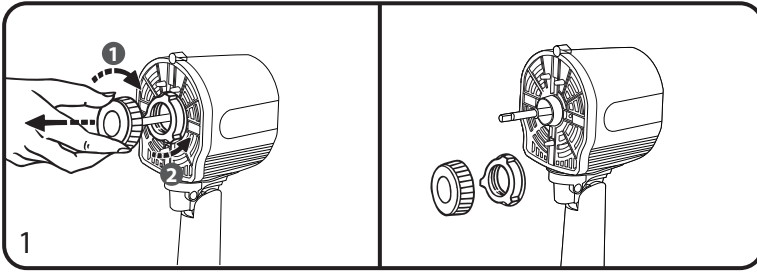

#3

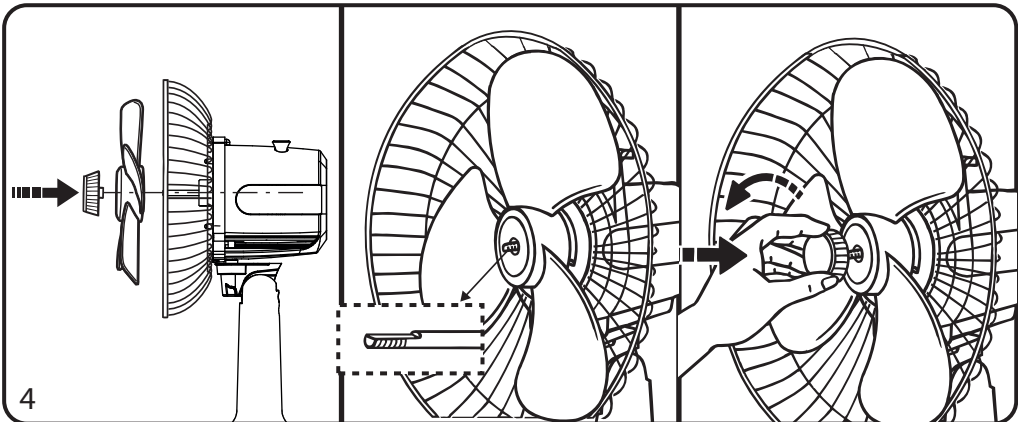

C

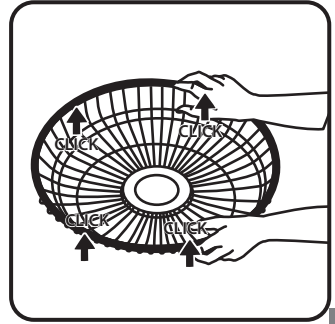
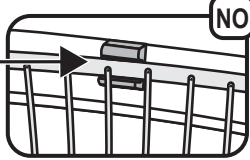
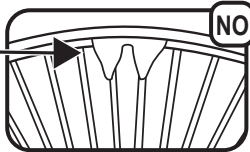
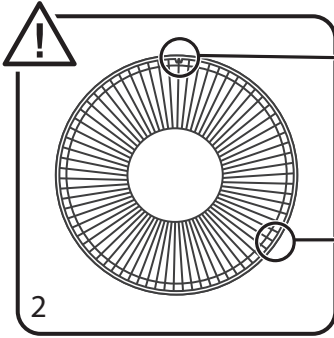
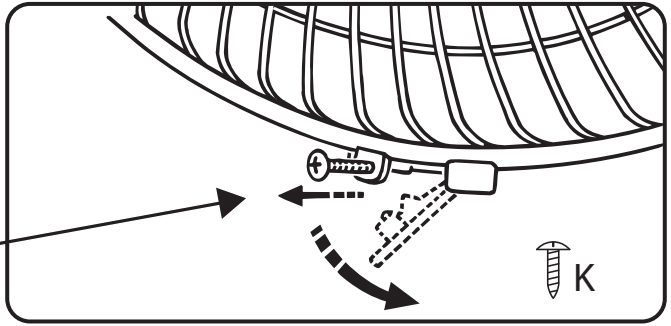
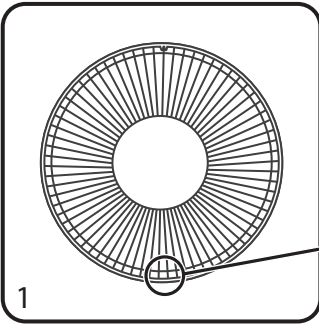

#3

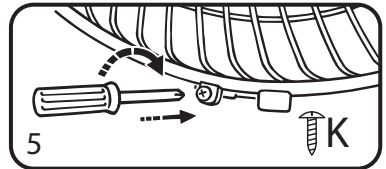
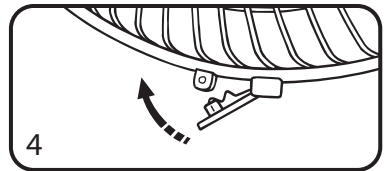
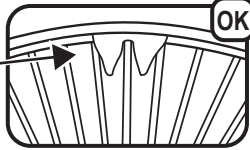
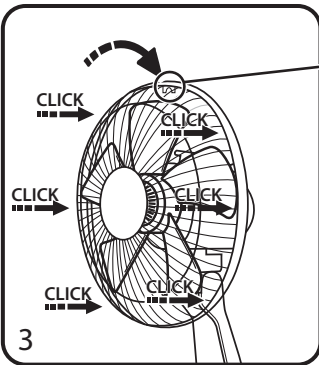
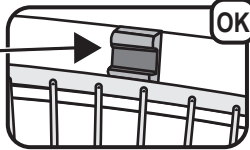
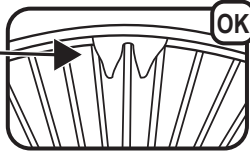
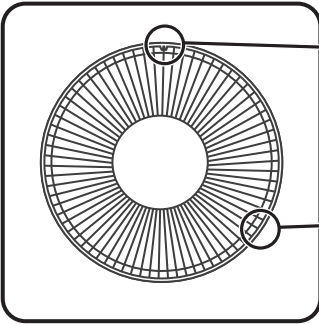

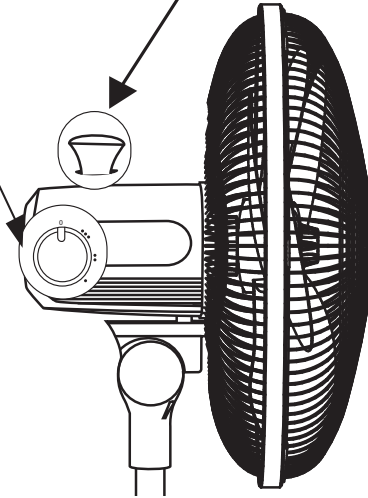
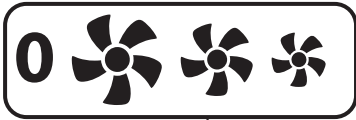
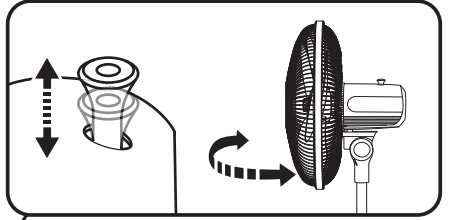
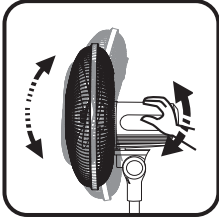
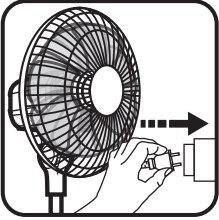

#3

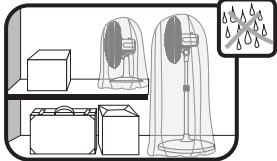
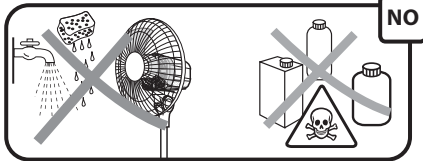

FR Veuillez lire attentivement le livret "Consignes de sécurité et d'utilisation" avant la première utilisation / EN Please read carefully the "Safety and use instructions" booklet before first use / DE Lesen Sie vor dem erstmaligen Gebrauch aufmerksam die Broschüre „Sicherheits- und Bedienungshinweise“ durch. / NL Gelieve vóór het eerste gebruik aandachtig het boekje met de veiligheids- en gebruiksvorschriften door te nemen / ES Lea detenidamente el libro «Instrucciones de seguridad y de uso» antes de utilizar el aparato por primera vez / PT Leia atentamente o manual «Instruções de segurança e utilização» antes da primeira utilização / IT Leggere con attenzione il libretto "Norme di sicurezza e d'uso" al primo utilizzo / DA Læs hæftet "Sikkerheds- og brugsanvisning" grundigt igennem inden den første ibrugtagning. / NO Les nøye heftet "Råd om sikkerhet og bruk" før første gangs bruk / SV Var god läs häftet "Säkerhets- och användningsinstruktioner" innan den första användningen. / FI Lue turvallisuu- ja käyttöohjevihko huolellisesti ennen ensimmäistä käyttökertaa. / TR İlk kullanımdan önce "Güvenlik ve kullanım talimatları" kitapçığını dikkatlice okuyun / EL Διαβάστε προσεκτικά το εγχειρίδιο «Οδηγίες ασφαλείας και χρήσης» πριν από την πρώτη χρήση / PL Przed pierwszym użyciem proszę uważnie przeczytać broszurę „Zalecenia dotyczące bezpieczeństwa i użytkowania” / CS Před prvním použitím si, prosím, pečlivě prostudujte „Bezpečnostní pokyny pro použití” / SK Pred prvým použitím si pozorne prečítajte „Bezpečnostné odporúčania a použitie”. / HU Az első használat előtt figyelmesen olvassa el a „Biztonsági előírások és használati útmutató” című fejezetet / SL Pred prvo uporabo natančno preberite »Navodila za varno uporabo« / RU Перед первым использованием внимательно прочитайте инструкцию «Меры безопасности и правила использования». / UK Перед першим використанням уважно прочитайте посібник «Правила техніки безпеки та рекомендації щодо використання» / HR Molimo da prije prve uporabe pažljivo pročitate priručnik „Sigurnosne upute” / RO Înainte de prima utilizare, citiți cu atenție manualul „Instrucțiuni de siguranță și de utilizare” / ET Palun lugege enne esimest korda kasutamist hoolikalt ohutus- ja kasutusjuhendit / LT Atidžiai perskaitykite knygelę „Saugos ir naudojimo reikalavimai” prieš naudodami įrenginį pirmą kartą / LV Pirms izmantojat ierīci pirmoreiz, lūdzu rūpīgi izlasiet brošūru "Norādījumi par drošību un lietošanu" / BG Моля, прочетете внимателно книжката "Препоръки за безопасност и употреба" преди първоначална употреба / SR Molimo vas da pročitate knjžicu «Sigurnost i korišćenje» pre prve upotrebe / BS Molimo vas da pročitate knjžicu «Sigurnost i upotreba» prije prve upotrebe / HK 於首次使用前，請詳閱安全使用手冊。 / MS Sila baca dengan teliti buku kecil "Arahan keselamatan dan penggunaan" sebelum digunakan buat pertama kali. / VI Đọc cẩn thận cẩm nang "Hướng dẫn về an toàn và cách sử dụng" trước khi dùng. /

FA لطفاً قبل از اولین استفاده به دقت دفترچه "توصیه های ایمنی و طرز استفاده" را مطالعه فرمایید. /

AR يرجى قراءة كتيب "إرشادات السلامة والاستخدام" جيداً قبل الاستخدام لأول مرة. /

TH กรุณาอ่านคู่มือ "คู่มือการใช้งานเพื่อความปลอดภัย" ก่อนการใช้งานครั้งแรก

FR Pour plus d'informations / EN For more information / DE Weitere Informationen / NL Voor meer informatie / ES Para más información / PT Para mais informações / IT Per ulteriori informazioni / DA Yderligere informationer / NO For ytterligere informasjon / SV För mer information / FI Lisätietoja /TR Daha fazla bilgi için / EL Για περισσότερες πληροφορίες / PL Więcej informacji można znaleźć / CS Více informací naleznete zde / SK Pre viac informácií / HU További információk / SL Več informacij / RU Для получения дополнительной информации / UK Для отримання докладніших відомостей / HR Za više informacija / RO Pentru informații suplimentare / ET Lisateave / LT Norėdami daugiau informacijos / LV Vairāk informācijas / BG За повече информация / SR za više informacija / BS za dodatne informacije / HK 想了解更多資訊 / MS Untuk mendapatkan maklumat lanjut / VI Thông tin chi tiết / FA برای اطلاعات بیشتر / لمزيد من المعلومات / TH หากต้องการข้อมูลเพิ่มเติม

