

Downloaded from www.vandenborst.nl

QARDIOCORE

WIRELESS ECG MONITOR
USER MANUAL



TABLE OF CONTENTS

Introduction	4	Wearing QardioCore upside down	14
Intended use	6	Comfortable fit for females	15
Important safety information	6	Taking an ECG/EKG recording	15
Features	8	Checklist for a correct and accurate ECG/EKG recording	15
Operational requirements	8	Visualizing your ECG/EKG data	16
Package contents	9	Important facts about ECG/EKG and self-measurement	16
Using QardioCore for the first time	10	Activity tracking	18
How to turn on/off QardioCore	12	Charging QardioCore	19
Detailed instructions for the correct fitting of QardioCore	12		

Resetting the pairing	20
Accuracy testing and maintenance	20
Cautions	21
Contraindications	22
User responsibility	22
General use, safety and precautions, cleaning	22
Customer service contact	26
Limited warranty	26
Error messages and troubleshooting	28

QardioCore technical specifications	30
Disposal	34
Certifications	34
FCC statement	36
RF statement	39



INTRODUCTION

Qardio offers a better way of tracking heart health that fits effortlessly into your life. Our devices are powerful and smart, have a beautiful design with a delightful user experience so you can use them anytime, anywhere.

QardioCore is a clinical-quality wearable electrocardiogram recorder. It records electrocardiogram (ECG/EKG) and physical activity.

Health conscious individuals or patients with known or suspected heart conditions can use QardioCore to record their daily ECGs, physical activity, sport performance and medical symptoms during the day or whenever they feel like, and share their data with their doctors. Medical professionals can use the QardioCore to quickly assess heart rate and rhythm, screen for arrhythmias, and remotely monitor and manage patients who use QardioCore. Athletes can use QardioCore to precisely track and analyze their sport cardiovascular performance.

QardioCore is the smart way to track your electrocardiogram with contextual information about your physical activity. This device was developed in collaboration with physicians and clinical tests were conducted to prove its measurement accuracy.

With its ease of use and accuracy, QardioCore is ideal for monitoring your ECG trace throughout the day. With this system, you can record your ECG over extensive periods of time. This allows your doctor to assess ECG traces accompanying intermittent or infrequent symptoms difficult to capture with conventional ECG and Holter systems.

QardioCore does not perform any automatic beat or rhythm classification on the acquired ECG data. The intended duration of use of the QardioCore is up to 24 hours.

Please read through these instructions carefully so you understand all functions and safety information.

We want you to be happy with your QardioCore. If you have any questions, problems or suggestions, please contact Qardio's Customer Service at support.getqardio.com, or visit our website www.getqardio.com for more information.

QardioCore has features that are only available to those users who are under the care of a physician. These features are available to prescription users only and may not be available in all regions or all languages.

INTENDED USE

The QardioCore wireless ECG monitor is a smartphone/tablet enabled device intended to record and transmit single-channel electrocardiogram (ECG).

The device does not perform any automatic beat or rhythm classification on the acquired ECG data. The intended duration of use of the device is up to 24 hours. The QardioCore is intended for use every day by clinician responsible for the patient's healthcare, patients with known or suspected heart conditions and health conscious individuals. The device is not intended for pediatric use.

The ECG report does not contain diagnostic interpretation, the reported analysis is provided for review by the intended user to render a diagnosis based on clinical judgment and experience. It is not intended to be a diagnostic device and may be useful for users who may be asymptomatic or who may have chest pain, palpitations, neurologic symptoms, shortness of breath, or to monitor response to treatment of cardiac disorders.

IMPORTANT SAFETY INFORMATION

- Please read the User Manual carefully before using the QardioCore ECG monitor.
- If you have a pacemaker or other internal electronic device, consult your physician before using an ECG monitor, like QardioCore.
- This device is not designed or intended for complete diagnosis of cardiac conditions. This device should never be used as a basis for starting or modifying treatment without independent confirmation by professional medical examination.
- Always consult your physician before you begin or modify any exercise program.
- This device does not detect or measure all heart rate, heart rhythm and heart waveform changes, especially those related to ischemic heart conditions.

- Do not attempt self-diagnosis or self-treatment based on the recording results and analysis.
- Interpretations made by this device are potential findings, not a complete diagnosis of cardiac conditions. All interpretations should be reviewed by a medical professional.
- Users should notify their doctor of a possible change in health: a labeling of the ECG as normal should not be relied on as a guarantee of absence of arrhythmias or other health conditions.
- The heart rate analysis is only valid if there is a valid rhythm (QRS complex visible).
- Do not use this device during an MRI scan.
- QardioCore relies on sensors that track your movement and other metrics. The data and information provided by this device is intended to be a close estimation of your activity and metrics tracked, but may not be completely accurate,

including step distance, and calorie data.

- ECG reports viewed or printed at any magnification other than 100% may appear distorted and could lead to misdiagnosis.
- Qardio does not recommend using QardioCore on humans less than 20kg.

FEATURES

QardioCore is designed to record, store and transfer [single-channel] electrocardiogram (ECG) rhythms. QardioCore also displays ECG rhythms and is designed for the assessment of symptoms that may be related to arrhythmias and the assessment of risk in patients with or without symptoms of arrhythmia (when prescribed or used under the care of a physician). QardioCore is intended for use by healthcare professionals, individuals with known or suspected heart conditions and health conscious individuals. The device has not been tested for and it is not intended for pediatric use.

QardioCore has features that are only available to those users who are under the care of a physician.

OPERATIONAL REQUIREMENTS

QardioCore requires a device with Bluetooth 4.0 (or later) and iOS 9.0 (or later) in order to use your QardioCore device, you:

Must download the free Qardio App from the Apple App Store, or go to www.getqardio.com

The first time you use QardioCore, an internet connection is required. You must sign up for a free Qardio account, via the Qardio App.

QardioCore works with iPhone 4S (or later), iPod Touch 5th gen (or later), iPad 3rd gen (or later), iPad Mini and iPad Air and Apple Watch OS2 (or later).

PACKAGE CONTENTS

You will find in your QardioCore package:

- a. QardioCore device
- b. Three chest straps, to facilitate your everyday use
- c. Charging cable
- d. Quick guide
- e. User manual

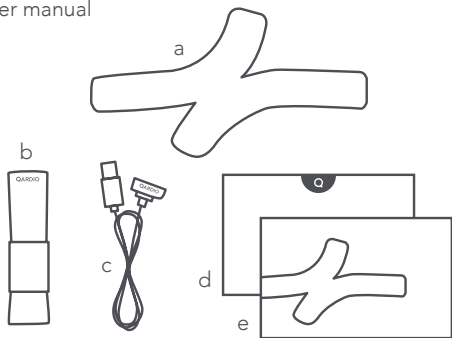

List of materials

1. QardioCore Cases: Acrylonitrile butadiene styrene (ABS) and Thermoplastic vulcanizates (TPV)
2. Connectors (Electrodes): Silver plated brass
3. Strap: 20% Nylon Wooly, 44% Spandex, and 36% Nylon
4. Buckles on the strap: Acrylonitrile butadiene styrene (ABS)
5. Rating label on the strap: 100% Polyester
6. Logo labels on the strap: 100% Nylon.

USING QARDIOCORE FOR THE FIRST TIME

1. Download the free Qardio App: On your mobile phone or tablet go to www.getqardio.com/ download and when prompted, download the app. Alternatively, go on the iTunes Store.
2. Open the Qardio App on your phone or tablet. If requested, you should enable Bluetooth on your device. You can enable Bluetooth under the Settings menu on your smartphone or tablet.
3. Create a new user login, or login with your existing user name and password. Follow the on-screen instructions to register and set up your personal account.
4. Connect QardioCore to one of the chest straps provided. Always connect the right side first.
5. Adjust the length of the strap to adapt it for your chest size.
6. Fit the QardioCore to your chest. You should wear QardioCore directly on your skin, just below your sternum. Wear your QardioCore with the Qardio logo to the left. All the electrodes should be touching your skin and QardioCore should be snug enough to stay in place during your movement.
7. When you connect the strap to the left side of QardioCore you should see a green light blink once to indicate that QardioCore has switched on.
8. While wearing QardioCore with the Qardio App open, touch and hold your phone or tablet to your chest to perform the pairing of your QardioCore with your phone or tablet. When prompted, accept the pairing request. The green light on your QardioCore will blink while the device is pairing, and the Qardio App will indicate your QardioCore has successfully paired.
9. After a few seconds, QardioCore will automatically start recording your electrocardiogram. Your ECG can be affected by the position of QardioCore on

your chest and your physiological condition. It is very important that QardioCore is correctly placed. Please read the “Detailed instructions for the correct fitting of QardioCore” and the “Checklist For a Correct and Accurate ECG/EKG Recording” sections on the User Manual with particular care.

10. The ECG recording can be stopped at any time by detaching the left clip from QardioCore and removing it from the chest.



Adjust length of strap

QardioCore should be snug enough to stay in place during your movement.

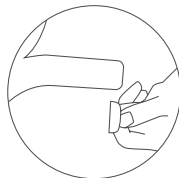

Slide the clip into place

Make sure QardioCore is fully touching your body, with all electrodes in contact with the skin, and the strap fits comfortably.

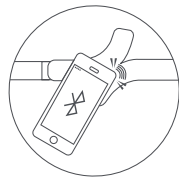

For the first time use only:

With the Qardio App open hold your iOS device near your QardioCore to pair it.

HOW TO TURN ON/OFF QARDIOCORE

QardioCore turns itself on when you attach the chest strap to its left side and it turns off when you unclip the left side of the strap. When QardioCore is not being worn, if the strap is left attached to the device, QardioCore will remain in a low power mode to preserve battery life.

To check if your device is switching on, look for the short blink of a green light on the top of the device when connecting the chest strap to the left side of QardioCore. The green light will blink twice when QardioCore is disconnected. Always store QardioCore with the chest strap detached from the device.

DETAILED INSTRUCTIONS FOR THE CORRECT FITTING OF QARDIOCORE

1. Wearing your QardioCore with the right fit will keep you comfortable: the device should be snug but comfortable, and it should remain in place during your movements. You should wear QardioCore directly on your skin, just below your sternum. An overly tight strap can be annoying or even cause skin irritation, while a strap that's too loose can cause rubbing and affect the performance of QardioCore. Before fitting QardioCore to your chest, connect the device to one of the chest straps provided. Always connect the right side (when viewing QardioCore from the sensor side) first.
2. Adjust the length of the strap to adapt it for your strap size.
3. Position QardioCore on your chest with the Qardio logo to the left. You should wear QardioCore directly on your skin, just below the sternum. Wrap

the strap around your body and connect it to the left side of QardioCore. All of the electrodes should be touching your skin and QardioCore should be fitted securely enough to stay in place during your movement.

4. After you put on QardioCore, it switches on automatically and starts recording the electrocardiogram after a few seconds. When you connect the strap to the left side of QardioCore, you should see a green light blink once to indicate that QardioCore has switched on.

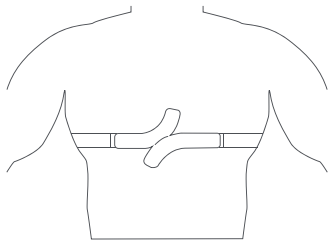

5. In order to obtain an accurate measurement, it is essential that all of QardioCore's electrodes remain in contact with your skin at all times. We have designed QardioCore to suit a multitude of body shapes and chest types, allowing for you to make slight modifications to how QardioCore is worn to maximize the recording quality and comfort on an individual level. If the ECG data is erratic or does not appear, you can try these tips:

- Clean and dry your chest before putting on the device.
- Avoid wearing sunscreen under the device.
- Wear the device below your sternum bone. The device should be snug but comfortable.
- You can try wearing the device lower on your chest.

6. Tips to avoid skin irritation, or if you have allergies or skin sensitivities.
- Keeping your QardioCore and straps—as well as your skin—clean and dry will maximize comfort and prevent long-term damage to the device. This is especially important after workouts or exposure to liquids such as sweat, soap, sunscreen, and lotions that can cause skin irritations.
 - These irritants can make skin reactions more likely if found between QardioCore and your skin.
 - If you have known allergies or sensitivities to substances like metals or plastics, check the materials in QardioCore and its straps on <https://support.getqardio.com>.
 - If you experience redness, swelling, itchiness, or any other irritation, immediately remove QardioCore and consult your physician before you put QardioCore back on.
- Ensure you allow your skin to breathe for a few hours a day by not wearing QardioCore.
 - Individuals with sensitive skin or in poor physical condition may experience skin irritation when wearing QardioCore. Such individuals should keep their QardioCore and straps particularly clean.

WEARING QARDIOCORE UPSIDE DOWN

If you have a more concave chest, or are consistently finding it difficult for the top electrode to remain in contact with the skin, we recommend that you wear QardioCore upside down. Unclip the strap from the left side of QardioCore and flip the device around so the Qardio logo is on the right side. Re-position QardioCore and re-attach the strap. Then, while in the QardioCore section of the Qardio App, open “Settings.” Click the button to turn on “Upside down wearing mode” before checking your ECG timeline for an improvement in recording quality.

COMFORTABLE FIT FOR FEMALES

QardioCore should be worn underneath the bra for an accurate reading. To ensure the most comfortable fit, QardioCore should be used with a wire-free bra or a sports bra.

TAKING AN ECG/EKG RECORDING

When you wear a fully charged QardioCore, it will automatically start recording your electrocardiogram after approximately one minute.

It is very important that QardioCore is correctly placed. Please read the "Detailed instructions for the correct fitting of QardioCore" and the "Checklist For a Correct and Accurate ECG/EKG Recording" sections of the User Manual with particular care. The ECG recording can be stopped at any time by detaching the left clip from QardioCore and removing it from the chest.

CHECKLIST FOR A CORRECT AND ACCURATE ECG/EKG RECORDING

- Adjust the length of the strap to adapt it for your chest size. Wear your QardioCore with the Qardio logo to the left.
- Fit the QardioCore to your chest. When you connect the strap to the left side of QardioCore you should see a green light blink once to indicate that QardioCore has switched on.
- You should wear QardioCore directly on your skin, just below your sternum. Ensure all the electrodes are touching your skin. Ensure QardioCore fits securely enough to stay in place during your movement.
- Ensure the Qardio App is running on your iOS device.
- You can stop the recording at any time by pressing the clip and detaching QardioCore from your chest. The green light will blink twice to indicate QardioCore has disconnected.

VISUALIZING YOUR ECG/EKG DATA

Press the ECG button while in the QardioCore section of Qardio App to see your ECG trace and heart rate data to see your ECG trace and heart rate data.

The ECG trace is visualized by default at 25mm/s and 10mm/mV. You can pinch and zoom when viewing the recording.

The ECG visualization can also be set to 25mm/s or 50mm/s, and 5mm/mV, 10mm/mV or 20mm/mV. These options are only available to health professionals.

NOTE: ECG recording viewed or printed at any magnification other than 100% may appear distorted and could lead to misdiagnosis.

NOTE: You will not be able to view your recordings or utilize any of QardioCore's analytical tools until you are under the care of a physician. To gain access to these features, you must create an account on the Qardio App. One minute of your first recording will then be automatically sent for analysis. Once you have

received the ECG analysis, you will have an access to viewing that recording and subsequent recordings. This service is not intended to replace medical advice, and please seek professional medical assistance if you are suffering from any medical problem.

IMPORTANT FACTS ABOUT ECG/EKG AND SELF-MEASUREMENT

What is an electrocardiogram?

An electrocardiogram – often abbreviated as ECG or EKG – is a test that measures the electrical activity of the heartbeat. With each heartbeat, an electrical impulse (or “wave”) travels through the heart. This wave causes the muscle to squeeze and pump blood from the heart.

Why is it done?

An ECG gives two major kinds of information. First, by measuring time intervals on the ECG, a doctor can determine how long the electrical wave takes to pass through the heart. Finding out how long the

wave takes to travel from one part of the heart to the next shows if the electrical activity is normal or slow, fast or irregular. Second, by measuring the amount of electrical activity passing through the heart muscle, a cardiologist may be able to find out if parts of the heart are too large or are overworked. During an ECG, several sensors, called electrodes, capture the electrical activity of the heart.

Wearing QardioCore during exercise

During exercise the body requires more oxygen. As the level of physical activity increases, the heart has to work harder to deliver more oxygen-rich blood to the exercising muscles, so the heart beats faster. By monitoring the electrical signals of the heart as it beats faster, it is often possible to detect coronary problems that cannot be seen when the body is at rest. As the intensity of the exercise increases, your heart rate will increase. You should stop your physical exercise if you experience dizziness, fatigue, chest pain, or other symptoms. Normally you should maintain your heart rate below your target level (85%

of a predicted maximum heart rate, based on your age, and your any known medical conditions). You should consult your doctor before exercising and about your target heart rate level.

Target heart rate

While using QardioCore, the Qardio App displays your current heart rate and the target heart rate during recording, in the overview area.

Target heart rate is a percentage of the predicted maximum heart rate. A target heart value that is 85% of the predicted maximum HR is indicative of hard physical activity.

The predicted maximum heart rate is calculated with the following formula: Predicted Maximum Heart Rate = $(220 - \text{user's age in years})$.

Heart rate detection method

1. ECG signal is filtered with a set of filters to amplify QRS parts of the signal and detect QRS complex. Each detected QRS complex is tested for valid amplitude, duration and refractory period from previous QRS complex.
2. RR interval is calculated between two consecutive valid QRS complexes as time difference between its maximal amplitude peaks. Each detected RR interval is tested for valid duration and heart rate is reported as reciprocal of each interval in minutes (bpm) if tests are passed.

Heart rate calculations

Overall Rhythm Heart Rates	Max	The maximum overall heart rate
	Min	The minimum overall heart rate
	Avg	The average overall heart rate

Pause determination

Pause is defined as an RR interval greater than 3 seconds.

ACTIVITY TRACKING

Turning on activity tracking

The activity tracking feature records your daily step count, distance traveled, intensity minutes, and calories burned for each recorded day. Your calories burned includes your base metabolism plus activity calories.

Activity goal

QardioCore sets automatically a goal of 10,000 steps per day. You can change your daily steps goal in the Qardio App settings. The Qardio App shows your progress toward your daily steps goal as you move during the day.

Intensity minutes

To improve your health, organizations such as the World Health Organization, the U.S. Centers for Disease Control and Prevention, the American Heart Association recommend at least 150 minutes per week of moderate intensity activity, such as brisk walking.

The Qardio App monitors your activity intensity and tracks your time spent moving in moderate to vigorous intensity activities. Move in at least 10 consecutive minutes of moderate to vigorous intensity activities to work toward achieving your weekly intensity minutes' goal. You should consult your doctor before undertaking intensity minutes.

CHARGING QARDIOCORE

First charge your QardioCore by connecting the charging cable to the device and connecting the cable to a USB power source. QardioCore will not work until the battery has enough power.

When you charge QardioCore, a small LED on the device will blink indicating the charge status:

- Blinking green light every two second indicates QardioCore is charging.
- Solid green light indicate QardioCore is fully charged.
- The green light will blink 3 times to indicate your QardioCore battery is running low and should be charged.

Qardio recommends charging your QardioCore battery daily.

RESETTING THE PAIRING

In order to reset the pairing, remove the anchor from the QardioCore and use a paper clip to press the button on the pinhole on the QardioCore. You should see a green light shining through. The green light will blink twice to indicate the pairing has been reset.

If necessary, go into the Settings of your phone or tablet, select the QardioCore and select "Forget this device".

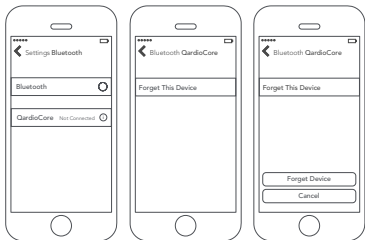

ACCURACY TESTING AND MAINTENANCE

QardioCore comprises sensitive components and must be treated with caution. Observe the storage and operating conditions described in the "Technical Specifications" section.

If you have a problem you cannot fix using the trouble shooting instructions, please contact Qardio customer service at <https://support.getqardio.com>.

We recommend the QardioCore be tested for accuracy every 2 years or after mechanical impact (e.g. being dropped). Please contact Qardio customer service at support@getqardio.com to arrange the test.

CAUTIONS

- Self-diagnosis of measurement results and self-treatment are potentially dangerous. You should always consult your doctor.
- If you suffer from an irregular heartbeat, measurements taken with this device should be evaluated with your doctor.
- This device may only be used for the purposes described in this User Manual. The manufacturer cannot be held liable for damage or injury caused by incorrect use. Always follow the operating procedures described in this User Manual.
- Radio Frequency (RF) interference between this device and any existing RF transmitting or receiving equipment at the installation site, including electrosurgical equipment, in close proximity to the cardiograph should be evaluated before the equipment is operated as they may seriously degrade performance.
- This device is susceptible to interference from RF energy sources (lowered RF immunity) which exceed the IEC 60601-1-2 limits, such as power line bursts, other medical devices, and certain cellular products, information technology equipment and radio/television transmission.
- Artifacts on the ECG caused by electromagnetic interference should be evaluated by a physician or physician authorized personnel to determine if it will negatively impact patient diagnosis or treatment.
- Like all electronic devices, this cardiograph is susceptible to electrostatic discharge (ESD). Electrostatic discharge typically occurs when electrostatic energy is transferred to the patient, the electrodes, or the cardiograph. ESD may result in ECG artifact that may appear as narrow spikes on the cardiograph display or on the printed report. When ESD occurs, the cardiograph's ECG interpretation may be inconsistent with the physician's interpretation.

- QardioCore has features that are only available to those users who are under the care of a physician. These features are available to prescription users only.
- QardioCore is not intended for use on an ambulance.

CONTRAINDICATIONS

- Do not use in case of potentially life-threatening arrhythmias requiring hospitalization, or when real time or in-patient monitoring should be prescribed.
- Do not use in combination with external cardiac defibrillator or high frequency surgical equipment, or near strong magnetic fields or devices such as MRI.
- Do not use in case of known skin allergies to any of the materials indicated in the "List of Patient-Contacting Materials".

USER RESPONSIBILITY

This product is designed to perform in conformity with the description thereof contained in this manual and accompanying documentation, when operated and maintained in compliance with the instructions provided. A defective product should not be used. Parts that are broken, plainly worn, distorted or contaminated should be replaced immediately. Should any repair or replacement become necessary, we recommend contacting Qardio Customer Support. The user of the product shall have the sole responsibility for any malfunction, which results from improper use, faulty maintenance, damage or alteration.

GENERAL USE, SAFETY AND PRECAUTIONS, CLEANING

- If you have a pacemaker or other internal electronic device, consult your physician before using QardioCore.

- Always consult your physician before beginning or modifying any exercise program.
- QardioCore is not intended to diagnose, cure, or prevent any disease or medical condition.
- QardioCore is not intended to be a replacement for a 12-lead ECG.
- While you wear the QardioCore, the recharging function will not work. Do not perform any modifications to QardioCore or its charging cable to allow wearing QardioCore while recharging.
- Do not use QardioCore for any purpose other than as specified in this User Manual.
- Do not leave QardioCore unattended around children or persons who cannot express their consent to use.
- Do not bend QardioCore.
- Do not apply strong shocks and vibrations to QardioCore, as this may result in damage to the device.
- Do not drop QardioCore.
- Do not expose QardioCore to temperatures outside the storage or operating range.
- Do not expose QardioCore to direct sunlight for extended periods of time.
- Do not disassemble, modify, remanufacture, puncture or damage QardioCore.
- Do not immerse or expose QardioCore to liquids, fire, explosion, or other hazard.
- Do not use a power cable that is not approved or supplied by Qardio.
- QardioCore has features that are only available to those users who are under the care of a physician. These features are available to prescription users only and may not be available in all regions or all languages.
- **QARDIOCORE SHOULD NOT BE USED IN CASE OF EMERGENCY. IN CASE OF EMERGENCY, IMMEDIATELY CONTACT YOUR LOCAL EMERGENCY SERVICES.**

- Certain services may give you the ability to request professional clinical interpretation and analysis of your ECG recordings. Your location may restrict your ability to use this service as certain telemedicine restrictions may apply to your area. Qardio does not know your location and it is your responsibility to ensure this service is legal according to your local telemedicine laws.

QardioCore dust and water resistance

Your QardioCore is dust resistant and splash and water resistant, but not waterproof (QardioCore has a water resistance rating of IP65 under IEC standard 60529). For example, you may wear and use your QardioCore during exercise (exposure to sweat is OK), in the rain, and while showering, but is not suitable for diving or swimming.

Submerging your QardioCore isn't recommended. Water resistance isn't a permanent condition, and your QardioCore can't be rechecked or resealed for water resistance. The following may affect the water resistance of your QardioCore and should be avoided:

- Dropping or bending your QardioCore or subjecting it to other impacts.
- Submerging your QardioCore in water for long periods of time.
- Swimming or bathing with your QardioCore.
- Exposing your QardioCore to pressurized water or high velocity water, for example, water skiing, wake boarding, surfing, jet skiing, and so on.
- Exposing your QardioCore to temperatures outside of its operating or storage range.
- Wearing your QardioCore in a sauna or steam room.

Cleaning

- Remember that you wear your QardioCore in contact with your skin, just like a clothing item. Because of this, you should always keep your QardioCore clean. Even if the surface of QardioCore appears clean, sweat, soap, sunscreen, and lotions on the surface or in crevasses can cause skin irritation.

- Keep your QardioCore clean and dry. A soft toothbrush or a nonabrasive, lint-free cloth to scrub it with a weak solution of fresh water and a mild neutral detergent.
- The bacteria and odor resistant QardioCore straps protect against odor generated by the formation of bacteria from sweat, which ensures good comfort and hygiene. In order to ensure maximum bacteria and odor resistance, keep your QardioCore and the straps clean.
- Cleaning products, and abrasive materials shouldn't be used on your QardioCore. Compressed air and external heat sources like hair dryers can cause damage.
- Direct sunlight, high temperatures, and humid conditions can cause damage.

To clean QardioCore, follow these steps:

1. Take off your QardioCore and keep the charging cable unplugged.
2. Clean your QardioCore with a soft toothbrush or a nonabrasive, lint-free cloth to scrub it with fresh water and a mild neutral detergent.
3. Dry your QardioCore with a nonabrasive, lint-free cloth.
4. To clean the QardioCore strap, wash it by hand or washing machine with a mild soap and cold water. Let the strap air dry.

CUSTOMER SERVICE CONTACT

Qardio customer service contact is available at <https://support.getqardio.com>.

LIMITED WARRANTY

This device is covered by a one year limited warranty from the date of purchase. Each strap has a functional warranty (elasticity) for one year, while battery and other wearing parts are not covered by the limited warranty.

The limited warranty is valid only on presentation of the purchase receipt confirming date of purchase. Opening or altering the device invalidates the limited warranty. This warranty applies only to purchases made by end users from Qardio and its authorized resellers. This warranty is void for purchases made from any other reseller, and Qardio offers no warranty for such purchases.

The guarantee does not cover damage caused by

improper handling, discharged batteries, accidents or non-compliance with the operating instructions and normal wearing of parts.

If a defect arises during the warranty period, Qardio, at its option and to the extent permitted by law will (1) repair the product at no charge, using new parts or parts that are equivalent to new in performance and reliability, (2) exchange the product with a functionally equivalent product that is new or equivalent to new in performance and reliability, or (3) refund the original purchase price. This warranty excludes damage resulting from abuse, accident, modifications or other causes that are not defects in materials and workmanship.

Other than the consumer law rights to which you are entitled, all warranties, conditions and other terms not set out in this warranty document are excluded from the limited warranty. Some countries do not allow limitations on how long such warranties, conditions and/or implied terms may last, so the limitations described above may not apply to you.

In no event shall Qardio be liable for (a) any losses that were not caused by our breach of this limited warranty; (b) any incidental, special, indirect or consequential damages, whether resulting from use, misuse, or inability to use this product or from defects in the product, (c) losses relating to any business of yours, loss of profits, loss of data or loss of opportunity.

The provisions of this limited warranty shall not apply to any other liability, except those that cannot be limited or excluded as a matter of law. Depending on where you live, some of the above limitations or exclusions may not apply to you. To obtain warranty service, contact Qardio at <https://support.getqardio.com>.

Online Auction Purchases: Products purchased through online auctions are not eligible for rebates or other special offers from Qardio warranty coverage. Online auction confirmations are not accepted for warranty verification. To obtain warranty service, an original or copy of the sales receipt from the original

retailer is required. Qardio will not replace missing components from any package purchased through an online auction.

Australian Purchases: Our goods come with guarantees that cannot be excluded under the Australian Consumer Law. You are entitled to a replacement or refund for a major failure and for compensation for any other reasonably foreseeable loss or damage. You are also entitled to have the goods repaired or replaced if the goods fail to be of acceptable quality and the failure does not amount to a major failure. The benefits under our Limited Warranty are in addition to other rights and remedies under applicable law in relation to the products.

ERROR MESSAGES AND TROUBLESHOOTING

Lead quality problems

The following table describes different lead quality problems and possible actions to try to resolve this:

Condition	Possible Causes	Actions
Bad signal	<ul style="list-style-type: none">• Poor electrode contact with skin.• Not all electrodes are touching.	<ul style="list-style-type: none">• Make sure QardioCore is fitting tightly and that all electrodes are touching the skin.
Wandering baseline (an upward and downward fluctuation of the waveforms)	<ul style="list-style-type: none">• Electrodes that are dirty, loose, or positioned on a bony area.• Oily skin or body lotions.• Rising and falling of chest during rapid or apprehensive breathing.• Not all electrodes are touching.	<ul style="list-style-type: none">• Clean skin with alcohol or acetone.• Reposition QardioCore higher (or lower) on the chest so that all electrodes are touching. User should relax.• If wandering baseline persists, go to Settings and ensure Baseline filter is turned on.

Condition	Possible Causes	Actions
<p>Muscle tremor interference (random irregular voltage superimposed on the waveforms). May resemble or coincide with AC interference</p>	<ul style="list-style-type: none">• User is uncomfortable, tense, nervous.• User is cold and shivering.• QardioCore strap is too tight.• Not all electrodes are touching.	<ul style="list-style-type: none">• User should get comfortable.• Ensure that all electrodes are touching the skin.• If interference still persists, the problem is probably electrical in nature. See the following suggestions for reducing AC interference.
<p>AC interference (even-peaked, regular voltage superimposed on the waveforms). May resemble or coincide with muscle tremor interference</p>	<ul style="list-style-type: none">• Electrodes that are dirty, loose, or positioned on a bony area.• Patient touching any metal objects.• Electrical devices in the immediate area, lighting, concealed wiring in walls or floors.• Improperly grounded electrical outlet nearby.• Incorrect AC filter frequency setting or AC filter is turned off.	<ul style="list-style-type: none">• Ensure that all electrodes are touching the skin.• Verify that the user is not touching any metal.• Verify that the proper AC filter is selected.• Try moving to another room.• If possible, unplug electrical devices in the immediate area.• If interference still persists, the noise may be caused by other equipment in the room or by poorly grounded power lines.

QARDIOCORE TECHNICAL SPECIFICATIONS

Chest size	27.5 - 43 in (70 - 109 cm)
Memory	Practically unlimited, when connected to smartphone or tablet. Up to 10 hours data storage when not connected to smartphone or tablet, depending on usage conditions.
ECG data compression	No data compression. All data is stored and transmitted in raw format.
ECG recording type	Continuous
ECG channel	Single channel
Input dynamic range	50mV Peak-to-Peak
DC dynamic span	$\pm 300\text{mV}$
Gain accuracy	5%

Differential range	+/-5mV
ECG amplitude resolution	0.8 μ V
ECG signal bandwidth	0.05 to 40 Hz
ECG A/D sampling rate	600 samples per second, internal sampling rate
ECG sampling resolution	16 bit
ECG common mode rejection	60dB
ECG input impedance	>100M Ω
ECG calibration	Automatic
Movement sensor	3-axis accelerometer

Power source	The device is powered by a built-in, 3.7V lithium-ion battery that you can charge using the charging cable supplied in the product package.
Battery life	24 hours of continuous recording, when fully charged.
Battery charge time	About 3 hours to 100%. Charge time depends on environmental factors; actual results will vary.
Water resistance	Water resistance rating of IP65 under IEC standard 60529
Weight (including strap)	130g (0.29lb) including the battery
Dimensions	185 x 87 x 9 mm (7.3 x 3.4 x 0.4 in)
Operating conditions	-20°C to 40°C (-4°F to 104°F) temperature for discharging and 0°C to 40°C (32°F to 104°F) temperature for charging, 25% to 90% (non-condensing) relative maximum humidity, atmospheric pressure 86~106kpa, maximum altitude: 3000m (9,842 ft)

Storage conditions

-20°C to 40°C (-4°F to 104°F) temperature, 45% to 85% (non condensing) relative maximum humidity, atmospheric pressure 86~106kpa, maximum altitude: 3000m (9,842 ft).

Shelf life

Estimated 2 years.

Specifications and features are subject to change without prior notice or any obligation for the manufacturer, and may not be available in all regions or all languages. Certain features may require purchase of separate services.

DISPOSAL

Actuation of European directives 2002/95/EC, 2002/96/EC and 2003/108/EC, for reduction in use of dangerous substances in the electric and electronic device and for garbage disposal. The symbol applied on the device or its packaging means that at the end of its useful life the product must not be disposed of with domestic waste.

At the end of devices useful life, the user must deliver it to the able collecting centers for electric and electronic garbage, or give back to the retailer when purchasing a new device. Disposing of the product separately prevents possible negative consequences for the environment and for health, deriving from inadequate disposal. It also allows the recovery of materials of which it's made up in order to obtain an important saving of energy and resources and to avoid negative effects to the environment and health. In case of abusive disposal of device by the user, will be applied administrative endorsements

in compliance with current standard. The device and its parts are made with regard to disposal, as appropriate, in accordance with national or regional regulations.

CERTIFICATIONS

This device complies with the following normative documents:

1. EN ISO 13485:2003 /AC: 2009: Medical devices - Quality management stems – Requirements for regulatory purposes (ISO 13485:2003) Reference to standards contd.
2. IEC/EN 60601-1-11:2010 General requirements for basic safety and essential performance –Collateral Standard: Requirements for medical electrical equipment and medical electrical systems used in the home healthcare environment
3. FCC part B 15B:2013 Electromagnetic Compatibility

4. FCC Rule Part: 15.247 Cat: DSS (Bluetooth) FCC Rule Part: 15.247 Cat: DTS (BT4.0)
5. EN ISO 10993-1:2009/AC:2010 Biological evaluation of medical devices - Part 1: Evaluation and testing within a risk management process (ISO 10993-1:2009)
6. EN ISO 10993-5:2009 Biological evaluation of medical devices - Part 5: Tests for in vitro cytotoxicity (ISO 10993-5:2009)
7. EN ISO 10993-10:2009 Biological evaluation of medical devices -- Part 10: Tests for irritation and skin sensitization
8. EN 55011 Group 1 Class B:2009+A1:2010 : Industrial, scientific and medical equipment - Radio-frequency disturbance characteristics - Limits and methods of measurement
9. IEC60601-1-2: Part 1-2: General requirements for basic safety and essential performance – Collateral Standard: Electromagnetic disturbances
10. IEC 60601-2-47 Ambulatory electrocardiographic monitors
11. ANSI/AAMI EC57: 2012 Testing and reporting performance results of cardiac rhythm and ST segment measurement algorithms
12. EN 300 328 V1.9.1: 2015 Electromagnetic compatibility and Radio Spectrum Matters (ERM); Wideband transmission systems; Data transmission equipment operating in the 2,4 GHz ISM band and using wide band modulation techniques; Harmonized EN covering the essential requirements of article 3.2 of the R&TTE Directive
13. EN 301 489-1 V1.9.2 (2011-09) Electromagnetic compatibility and Radio Spectrum Matters (ERM); ElectroMagnetic Compatibility (EMC) standard for radio equipment and services; Part 1: Common technical requirements
14. EN301489-17 V2.2.1:2012 Electromagnetic compatibility and Radio spectrum Matters (ERM); ElectroMagnetic Compatibility (EMC) standard for

radio equipment; Part 17: Specific conditions for Broadband Data Transmission Systems

- 15. IEC 62133:2012 RLV: Secondary cells and batteries containing alkaline or other non-acid electrolytes - Safety requirements for portable sealed secondary cells, and for batteries made from them, for use in portable applications
- 16. UN38.3, Fifth Edition: Recommendations on transport of dangerous goods, manual of test and criteria, Section 38.3 – Lithium metal and lithium ion batteries
- 17. EN 62366: Medical devices. Application of usability engineering to medical devices
- 18. IEC 60601-1-6: Medical electrical equipment - Part 1-6: General requirements for basic safety and essential performance - Collateral standard: Usability
- 19. IEC 62304:2006 Medical device software - Software life cycle process

FCC STATEMENT

Federal Communications Commission (FCC)
Statement 15.21

You are cautioned that changes or modifications not expressly approved by the part responsible for compliance could void the user's authority to operate the equipment.
15.105(b)

This equipment has been tested and found to comply with the limits for a Class B digital device, pursuant to part 15 of the FCC rules. These limits are designed to provide reasonable protection against harmful interference in a residential installation. This equipment generates, uses and can radiate radio frequency energy and, if not installed and used in accordance with the instructions, may cause harmful interference to radio communications. However, there is no guarantee that interference will not occur in a particular installation.

If this equipment does cause harmful interference to radio or television reception, which can be determined by turning the equipment off and on, the user is encouraged to try to correct the interference by one or more of the following measures:

- Reorient or relocate the receiving antenna. Increase the separation between the equipment and receiver.
- Connect the equipment into an outlet on a circuit different from that to which the receiver is connected.
- Consult the dealer or an experienced radio/TV technician for help.

A. This device complies with Part 15 of the FCC Rules/ Industry Canada license-exempt RSS standard(s). Operation is subject to the following two conditions:

- 1) This device may not cause harmful interference and
- 2) This device must accept any interference received, including interference that may cause undesired

operation of the device.

B. This device and its antenna(s) must not be co-located or operating in conjunction with any other antenna or transmitter.

C. Changes or modifications to this unit not expressly approved by the party responsible for compliance could void the user authority to operate this equipment.

IMPORTANT NOTE (for portable device configuration):

Federal Communication Commission (FCC) Radiation Exposure Statement. This EUT is in compliance with SAR for general population/uncontrolled exposure limits in ANSI/IEEE C95.1-1999 and has been tested in accordance with the measurement methods and procedures specified in OET Bulletin 65 Supplement C.

Le présent appareil est conforme aux CNR d'Industrie Canada applicables aux appareils radio exempts

de license. L'exploitation est autorisée aux deux conditions suivantes:

- 1) il ne doit pas produire de brouillage et
- 2) L'utilisateur du dispositif doit être prêt à recevoir tout brouillage radioélectrique reçu, même si ce brouillage est susceptible de compromettre le fonctionnement du dispositif.

ICES-003.

This Class B digital apparatus complies with Canadian ICES-003.

Cet appareil numérique de la classe B est conforme à la norme NMB-003 du Canada.

FCC RF Radiation Exposure Statement:

This equipment complies with FCC radiation exposure limits set forth for an uncontrolled environment. End users must follow the specific operating instructions for satisfying RF exposure compliance. This transmitter

must not be co-located or operating in conjunction with any other antenna or transmitter.

IC Radiation Exposure Statement / IC Déclaration sur la radioexposition.

This EUT is in compliance with SAR for general population-uncontrolled exposure limits in IC RSS-102 and has been tested in accordance with the measurement methods and procedures specified in IEEE 1528. This equipment should be installed and operated with minimum distance of 1.5cm between the radiator and your body.

Cet appareil est conforme avec SAR pour la population générale/limites d'exposition abusive IC RSS-102 et a été testé en conformité avec les méthodes et procédures spécifiées dans la norme IEEE 1528 mesure. Cet équipement doit être installé et utilisé à une distance minimale de 1,5cm entre le radiateur et votre corps. La séparation de test SAR de la distance de 10mm pour hotspot.

Under Industry Canada regulations, this radio transmitter may only operate using an antenna of a type and maximum (or lesser) gain approved for the transmitter by Industry Canada. To reduce potential radio interference to other users, the antenna type and its gain should be so chosen that the equivalent isotropically radiated power (e.i.r.p.) is not more than that necessary for successful communication.

En vertu de la réglementation de l'Industrie du Canada, cet émetteur de radio ne peuvent fonctionner en utilisant une antenne d'un type et maximum (ou moins) gain approuvé pour l'émetteur par Industrie du Canada. Pour réduire le risque de brouillage aux autres utilisateurs, le type d'antenne et son gain doivent être choisis de sorte que la puissance isotrope rayonnée équivalente (p.i.r.e.) ne dépasse pas ce qui est nécessaire pour la réussite de communication.

RF STATEMENT

Medical Electrical Equipment needs special precautions regarding EMC and needs to be installed and put into service according to the EMC information provided in the following section.

Interference may occur in the vicinity of equipment marked with the following symbol .

Portable and mobile RF communication equipment (e.g. cell phones) can affect Medical Electrical Equipment. The use of accessories and cables other than those specified may result in increased emissions or decreased immunity.

The device uses RF energy only for its internal function. Therefore, its RF emissions are very low and are not likely to cause any interference in nearby electronic equipment.

The device is suitable for use in all establishments, including domestic establishments and those directly connected to the public low voltage power supply network that supplies buildings used for domestic purposes.

Portable and mobile RF communications equipment should be used no closer to any part of the device, including cables, than the recommended separation distance calculated from the equation applicable to the frequency of the transmitter.

The device is intended for use in an electromagnetic environment in which radiated RF disturbances are controlled. Any other accessories, transducers and cables may result in increased emissions or decreased immunity and EMC performance.

The device should not be used adjacent to or stacked with other equipment and if adjacent or stacked use is necessary, it should be observed in order to verify normal operation in the configuration in which it will be used.

Medical Electrical Equipment needs special precautions regarding EMC and needs to be installed and put into service according to the EMC information provided in the following. Portable and mobile RF communication equipment (e.g. cell phones) can affect Medical Electrical Equipment. The use of accessories and cables other than those specified may result in increased emissions or decreased immunity of the unit.

Information in this document is subject to change without notice. All changes will be in compliance with regulations governing manufacture of medical equipment. Qardio reserves the right to change or improve its products and to make changes in the content of its User Manuals without obligation to notify any person or organization of any such changes or improvements.

Visit the Qardio website (www.getqardio.com) for current updates and supplemental information concerning the use and operation of this and other Qardio products.

Guidance and manufacturer's declaration-electromagnetic emissions

The QardioCore Wireless ECG Monitor system is intended for use in the electromagnetic environment specified below. The customer or the user of the QardioCore Wireless ECG Monitor system should ensure that it is used in such an environment.

Emissions test	Compliance	Electromagnetic environment - guidance
CE emissions CISPR11	Group 1	The QardioCore Wireless ECG Monitor uses RF energy only for its internal function. Therefore, its RF emissions are very low and are not likely to cause any interference in nearby electronic equipment.
RE emissions CISPR11	Class B	
Harmonic emissions IEC 61000-3-2	Not applicable	The QardioCore Wireless ECG Monitor is suitable for use in all establishments, including domestic establishments and those directly connected to the public low-voltage power supply network that supplies buildings used for domestic purposes.
Voltage fluctuations/ Flicker emissions IEC 61000-3-3	Not applicable	

Designed by and manufactured for Qardio, Inc. California, USA.
FOR US AND INTERNATIONAL

www.getqardio.com



Type BF Applied Part



YA HORNG ELECTRONIC CO., LTD.
No. 35, Shaun, Anding Dist., Tainan City 745, Taiwan
Factory: ATTEN ELECTRONIC (DONGGUAN) CO., LTD.
188 Industrial District, Ping Shan Administrative District,
Tang Shia Town, Dongguan, 190, CN, 518055



FCC ID: 2ABF2-888CORE
IC: 11885A-888CORE



2017



Read this manual before use.

US Importer

Qardio, Inc. 115 Sansome St Suite 1005
San Francisco, California 94104, USA.



WEEE

CE 2460

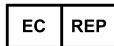

Kahl Handelsvertretung
Add.: Isarstr.33 40699 Erkrath, Germany

Designed by and manufactured for Qardio, Inc. California, USA.
FOR CANADA

www.getqardio.com



Type BF Applied Part



Factory: ATTEN ELECTRONIC (DONGGUAN) CO., LTD.
188 Industrial District, Ping Shan Administrative District,
Tang Shia Town, Dongguan, 190, CN, 518055



FCC ID: 2ABF2-888CORE
IC: 11885A-888CORE



2017



Read this manual before use.

US Importer

Qardio, Inc. 115 Sansome St Suite 1005
San Francisco, California 94104, USA.



WEEE

CE 2460

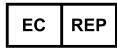

Kahl Handelsvertretung
Add.: Isarstr.33 40699 Erkrath, Germany

Declaration – electromagnetic emissions and immunity for equipment and systems that are not life-supporting and are specified for use only in a shielded location

The QardioCore Wireless ECG Monitor system declaration-electromagnetic immunity

The QardioCore Wireless ECG Monitor system is intended for use in the electromagnetic environment specified below. The customer or the user of the QardioCore Wireless ECG Monitor system should ensure that it is used in such an environment.

Immunity test	IEC 60601 test level	Compliance level	Electromagnetic environment - guidance
Conducted RF IEC 61000-4-6	3 Vrms 150 kHz to 80 MHz	3V	Portable and mobile RF communications equipment should be used no closer to any part of the EQUIPMENT or SYSTEM including cables, than the recommended separation distance calculated from the equation applicable to the frequency of the transmitter. Interference may occur in the vicinity of equipment marked with the following symbol 
Radiated RF IEC 61000-4-3	3 V/m 80 MHz to 2.5 GHz	3V/m 385 MHz 5 V/m 450 MHz 10 V/m 810 to 930 MHz 20 V/m	

Declaration – electromagnetic immunity

The QardioCore Wireless ECG Monitor system is intended for use in the electromagnetic environment specified below. The customer or the user of the QardioCore Wireless ECG Monitor system should ensure that it is used in such an environment.

Immunity test	IEC 60601 test level	Compliance level	Electromagnetic environment - guidance
Electrostatic discharge (ESD) IEC 61000-4-2	8 kV contact 15 kV air	8 kV contact 15 kV air	Floors should be wood, concrete or ceramic tile. If floors are covered with synthetic material, the relative humidity should be at least 30 %.
Electrical fast transient/burst IEC 61000-4-4	2 kV for power supply lines 1 kV for input/output lines	N/A	Mains power quality should be that of a typical commercial or hospital environment.
Surge IEC 61000-4-5	1 kV differential mode 2 kV common mode	N/A	Mains power quality should be that of a typical commercial or hospital environment.
Voltage dips, short interruptions and voltage variations on power supply input lines IEC 61000-4-11	-5 % UT(95 % dip in UT) for 0.5 cycle -40 % UT(60 % dip in UT) for 5 cycles -70 % UT(30 % dip in UT) for 25 cycles -5 % UT(95 % dip in UT) for 5 sec	N/A	Mains power quality should be that of a typical commercial or hospital environment. If the user of the EQUIPMENT or SYSTEM requires continued operation during power mains interruptions, it is recommended that the EQUIPMENT or SYSTEM be powered from an uninterruptible power supply or a battery.
Power frequency (50/60 Hz) magnetic field IEC 61000-4-8	30 A/m	30 A/m	Power frequency magnetic fields should be at levels characteristic of a typical location in a typical commercial or hospital environment.

Qardio, QardioArm, QardioBase, QardioCore, QardioMD and their respective logos are either registered trademarks or trademarks of Qardio, Inc. in the United States and/or other countries.

iPhone, iPad, iPod are trademarks of Apple Inc., registered in the U.S. and other countries.

The Bluetooth® word mark and logos are registered trademarks owned by Bluetooth SIG, Inc. and any use of such marks by Qardio, Inc. is under license. All other trademarks are properties of their respected owners.

Qardio products should be only used in conjunction with professional medical advice for diagnosis or treatment, and not as a substitute or replacement of it. Patents assigned and pending.