

PROLINE

# FOUR POSABLE MINI-OVEN

PMO30



## MANUEL D'UTILISATION HANDLEIDING

FR

NL

EN







ES

PT





# TABLE DES MATIÈRES

-  MISES EN GARDE IMPORTANTES..... p. 02
-  DESCRIPTION DU PRODUIT..... p. 05
-  AVANT LA PREMIÈRE UTILISATION..... p. 06
-  UTILISATION ..... p. 06
-  NETTOYAGE ET ENTRETIEN..... p. 09
-  SPÉCIFICATIONS..... p. 10
-  MISE AU REBUT ..... p. 11



FR

NL

EN

ES

PT

01





## **⚠ MISES EN GARDE IMPORTANTES**

**MERCI DE BIEN VOULOIR LIRE LES CONSIGNES DE SÉCURITÉ  
ATTENTIVEMENT AVANT D'UTILISER L'APPAREIL ET  
CONSERVER POUR RÉFÉRENCE ULTÉRIEURE.**

### **AVERTISSEMENTS**

- Cet appareil est destiné à être utilisé dans des applications domestiques et analogues telles que:
  - les coins cuisines réservés au personnel des magasins, bureaux et autres environnements professionnels;
  - les fermes;
  - l'utilisation par les clients des hôtels, motels et autres environnements à caractère résidentiel;
  - les environnements de type chambre d'hôtes.
- Si le câble d'alimentation est endommagé, il doit être remplacé par le fabricant, son service après vente ou des personnes de qualification similaire afin d'éviter un danger.
- Cet appareil peut être utilisé par des enfants à partir de 8 ans et plus et par des personnes ayant des capacités physiques, sensorielles ou mentales réduites ou un manque d'expérience et de connaissances à condition qu'elles aient reçu une supervision ou des instructions concernant l'utilisation de l'appareil en toute sécurité et qu'elles comprennent les dangers encourus.  
Les enfants ne doivent pas jouer avec l'appareil.  
Le nettoyage et l'entretien par l'utilisateur ne doivent pas être effectués par des enfants, sauf s'ils ont plus de 8 ans et qu'ils sont surveillés.
- Maintenir l'appareil et son cordon hors de portée des enfants de moins de 8 ans.
- Cet appareil n'est pas destiné à être mis en fonctionnement au moyen d'une minuterie extérieure ou par un système de commande à distance séparé.
- La température des surfaces accessibles peut être élevée lorsque l'appareil est en fonctionnement.
- La porte ou la surface extérieure peut devenir chaude lorsque l'appareil fonctionne.





- Ne pas placer l'appareil près de ou sur une gazinière ou une plaque chauffante, ne le posez pas sur un four ou un mini-four.
- En ce qui concerne les informations détaillées sur la manière de nettoyer les surfaces en contact avec les aliments, référez-vous dans la section "NETTOYAGE ET ENTRETIEN" en page 09.



- **Attention, surface très chaude**  
Les surfaces sont susceptibles de devenir chaudes au cours de l'utilisation.

## CONSIGNES DE SÉCURITÉ

- N'immergez pas le cordon, la fiche ou toute autre partie de l'appareil dans l'eau ou dans d'autres liquides.
- Ne laissez pas le câble d'alimentation pendre du bord d'une table ou d'un comptoir ou toucher des surfaces chaudes.
- Lorsque vous utilisez le four, laissez un espace d'au moins 10 cm de chaque côté du four pour permettre une circulation d'air adéquate.
- Pour débrancher l'appareil, tournez le bouton de commande des fonctions sur la position Off (arrêt) avant de retirer la fiche.
- Débranchez la fiche de la prise secteur lorsque vous ne l'utilisez pas et avant de la nettoyer. Saisissez toujours la prise pour débrancher l'appareil. Ne tirez jamais sur le câble d'alimentation.
- Laissez refroidir l'appareil avant de mettre ou d'enlever des pièces et avant de le nettoyer.
- Faites preuve d'une extrême prudence lorsque vous déplacez un appareil contenant de l'huile ou des aliments chauds.
- Ne couvrez aucune partie du four avec du métal ou un tissu, cela pourrait provoquer une surchauffe du four.
- Ne posez aucun objet sur le four et ne le couvrez pas.
- Soyez extrêmement prudent(e) lorsque vous retirez le plateau ou que vous jetez de la graisse chaude ou d'autres liquides chauds.
- Ne laissez pas l'appareil sans surveillance lorsqu'il est en marche.
- Les aliments surdimensionnés et les ustensiles métalliques ne



doivent pas être insérés dans le four, car ils peuvent provoquer un incendie ou un risque de choc électrique.

- Il convient d'être extrêmement prudent(e) lors de l'utilisation de récipients fabriqués dans des matériaux autres que le métal ou la céramique.
- Ne placez aucun des matériaux suivants dans le four : plastique, papier ou tout autre matériau similaire.
- N'utilisez pas d'accessoires autres que ceux recommandés par le fabricant dans ce four.
- Portez toujours des gants de protection isolants lorsque vous mettez des aliments dans le four chaud et lorsque vous les sortez.
- Les enfants doivent rester sous surveillance afin de garantir qu'ils ne jouent pas avec l'appareil.
- Cet appareil n'est pas destiné à une utilisation en plein air.
- L'appareil est conçu exclusivement pour un usage domestique. N'utilisez pas cet appareil pour une utilisation autre que celle pour laquelle il a été conçu.
- La porte vitrée est lourde, veuillez tenir la poignée jusqu'à ce que la porte soit complètement ouverte, ne laissez pas la porte tomber toute seule.



## DESCRIPTION DU PRODUIT

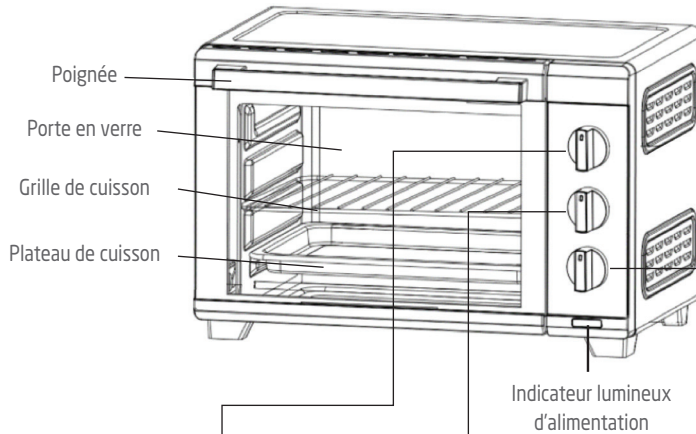

Bouton de contrôle de la température



Bouton de contrôle des fonctions



Bouton du minuteur



### Plateau de cuisson

Pour griller et rôtir la viande, la volaille, le poisson et divers autres aliments, ainsi que pour recueillir les résidus alimentaires lorsqu'elle est utilisée comme lèche-frite. Utilisez-le sur les rails centraux et inférieurs de l'appareil.

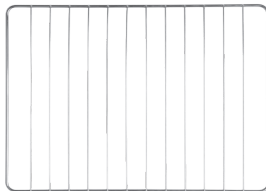

### Grille de cuisson

Pour griller, cuire au four, rôtir et cuisiner en général avec d'autres récipients en métal ou en verre résistant au four. Utilisez-la sur les rails supérieurs, centraux et inférieurs de l'appareil.

FR

NL

EN

ES

PT

05





## AVANT LA PREMIÈRE UTILISATION

Retirez tous les éléments d'emballage.

Lavez la grille de cuisson et le plateau de cuisson à l'eau chaude savonneuse.

Rincez-la et séchez-la soigneusement.

Essuyez l'extérieur du four avec un chiffon légèrement humide. N'immergez jamais l'appareil dans l'eau.

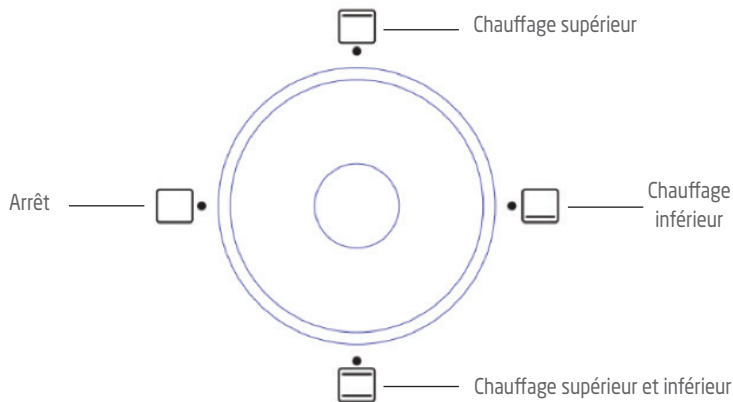

## UTILISATION

1. Placez le four sur une surface propre, plane et résistante à la chaleur.
  - Assurez-vous que la ventilation autour du four est suffisante.
  - Assurez-vous que le four est complètement sec avant de l'utiliser.
  - Le four ne doit pas être placé sur une surface en bois non traité.
2. Branchez le four.
3. Tournez le bouton de réglage de la température sur la température souhaitée entre 100°C et 230°C.
4. Tournez le bouton de contrôle des fonctions sur la position souhaitée.







	Lorsque vous utilisez cette fonction, seuls les éléments chauffants supérieurs sont utilisés. Placez les aliments sur la grille de cuisson. Placez la grille de cuisson sur les rails supérieurs du four tandis que la plaque de cuisson est placée sur les rails centraux du four.
	Lorsque vous utilisez cette fonction, seuls les éléments chauffants inférieurs sont utilisés. Placez les aliments sur la grille de cuisson ou la plaque de cuisson. Si vous utilisez la grille de cuisson, placez-la sur les rails centraux du four tandis que la plaque de cuisson est placée sur les rails inférieurs du four, si nécessaire.
	Lorsque vous utilisez cette fonction, les éléments chauffants supérieurs et inférieurs sont utilisés. Placez les aliments sur la grille de cuisson ou la plaque de cuisson. Si vous utilisez la grille de cuisson, placez-la sur les rails centraux du four tandis que la plaque de cuisson est placée sur les rails inférieurs du four, si nécessaire.

5. Tournez le bouton de commande de la minuterie sur la durée de cuisson souhaitée.

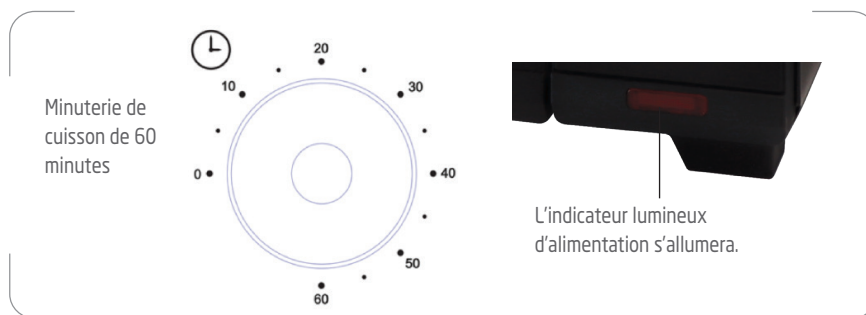

6. Lorsque la durée de cuisson est écoulée, une sonnerie retentit pour indiquer que le cycle de cuisson est terminé.
  - L'indicateur lumineux de fonctionnement s'éteindra.
  - Avant que la durée de cuisson programmée ne soit atteinte, vous pouvez tourner le bouton de commande de la minuterie sur la position 0 pour terminer la cuisson.

#### REMARQUE :

- Lors de la première utilisation du four, ce dernier peut produire une odeur et émettre de la fumée. Le four est en train de brûler les huiles en excès dans les éléments chauffants et ce phénomène est normal. Après 5 à 10 minutes,

FR

NL

EN

ES

PT

07





la fumée disparaît.

- Afin d'obtenir de meilleures performances de cuisson, il est recommandé de préchauffer le four pendant 10 à 15 minutes.

### Cuisson au gril

- Laissez la porte en position ouverte.
- Tournez le bouton de commande des fonctions sur le réglage GRILL .
- Tournez le bouton de réglage de la température sur 230 °C.
- Tournez le bouton de réglage de la minuterie sur la durée de cuisson souhaitée.
- Lorsque la cuisson au gril est terminée, tournez le bouton de commande de la minuterie sur la position 0 pour éteindre le four.

### Après utilisation

Remettez le bouton de commande de la minuterie sur la position 0.

Tournez le bouton de commande des fonctions sur la position Off (Arrêt).

Débranchez le four de la prise de courant.

Attendez que le four soit complètement refroidi avant de procéder à tout nettoyage ou entretien.



## **NETTOYAGE ET ENTRETIEN**

Débranchez l'appareil et laissez-le refroidir avant de le nettoyer.  
N'immergez pas l'appareil dans l'eau. Toutes les surfaces peuvent être nettoyées avec un chiffon propre et humide.  
Nettoyez la cavité intérieure avec un chiffon propre et humide.  
Lavez la grille de cuisson et le plateau de cuisson à l'eau chaude savonneuse. Rincez-la et séchez-la soigneusement.  
N'utilisez jamais de produits de nettoyage abrasifs ou chimiques.

Les surfaces en contact avec les aliments doivent être nettoyées régulièrement pour éviter la contamination croisée des différents types d'aliments. Il est conseillé d'utiliser un chiffon humide pour nettoyer les surfaces entrant en contact avec les aliments.

Les bonnes pratiques d'hygiène alimentaire doivent toujours être respectées à tout moment pour éviter les risques d'intoxication alimentaire ou de contamination croisée.

Séchez soigneusement toutes les pièces et surfaces avant de les utiliser.  
Assurez-vous que toutes les pièces et surfaces sont complètement sèches avant de brancher l'appareil.



## SPÉCIFICATIONS

Caractéristiques nominales : 220-240 V~, 50-60 Hz  
1600 W



<b>Dimensions (dimensions extérieures)</b>	(H) 325 x (L) 518 x (P) 378 mm
<b>Dimensions (cavité / dimensions intérieures)</b>	(H) 270.2 x (L) 369 x (P) 291 mm
<b>Poids (approx.)</b>	7.3 kg



## MISE AU REBUT



En tant que distributeur responsable, nous accordons une grande importance à la protection de l'environnement.

Nous vous encourageons à respecter les procédures correctes de mise au rebut de votre appareil, des piles et des éléments d'emballage. Cela aidera à préserver les ressources naturelles et à garantir qu'il soit recyclé d'une manière respectueuse de la santé et de l'environnement.

Vous devez jeter ce produit et son emballage selon les lois et les règles locales. Puisque ce produit contient des composants électroniques et parfois des piles, le produit et ses accessoires doivent être jetés séparément des déchets domestiques lorsque le produit est en fin de vie.

Pour plus de renseignements sur les procédures de mise au rebut et de recyclage, contactez les autorités de votre commune.

Apportez l'appareil à un point de collecte local pour qu'il soit recyclé. Certains centres acceptent les produits gratuitement.

### **Hotline Darty France**

Quels que soient votre panne et le lieu d'achat de votre produit en France, avant de vous déplacer en magasin Darty, appelez le 0 978 970 970 (prix d'un appel local) 7j/7 et 24h/24.

### **Hotline Vanden Borre**

Le service après-vente est joignable au +32 2 334 00 00, du lundi au samedi de 8h à 18h.

### **Hotline Fnac France**

Quels que soient votre panne et le lieu d'achat de votre produit en France, avant de vous déplacer en magasin Fnac, appelez le 0 969 324 334 du lundi au samedi (8h30-21h00) et le dimanche et jours fériés (10h00-18h00). (prix d'un appel local)

FR

NL

EN

ES

PT

11











En raison des mises au point et améliorations constamment apportées à nos produits, de petites incohérences peuvent apparaître dans ces instructions. Veuillez nous excuser pour la gêne occasionnée.

Etablissements Darty & fils ©,  
9 Rue des Bateaux-Lavois, 94200 Ivry-sur-Seine, France 08/04/2022





## INHOUDSOPGAVE

	BELANGRIJKE VEILIGHEIDSINSTRUCTIES.....	p. 14
	PRODUCTOVERZICHT.....	p. 17
	VOOR HET EERSTE GEBRUIK.....	p. 18
	GEBRUIK.....	p. 18
	REINIGING EN ONDERHOUD.....	p. 21
	SPECIFICATIES.....	p. 22
	VERWIJDERING.....	p. 23



FR

NL

EN

ES

PT

13





## **⚠ BELANGRIJKE VEILIGHEIDSINSTRUCTIES**

**LEES DE VOLGENDE VEILIGHEIDSINSTRUCTIES AANDACHTIG DOOR VOORDAT U HET APPARAAT IN GEBRUIK NEEMT EN BEWAAR ZE VOOR TOEKOMSTIG GEBRUIK.**

### **WAARSCHUWINGEN**

- Dit apparaat is bedoeld voor huishoudelijk gebruik en gebruik in andere vergelijkbare omgevingen, zoals:
  - personeelskeukens in winkels, kantoren en
  - andere werkomgevingen;
  - door klanten in hotels, motels en andere residentiële omgevingen;
  - bed-and-breakfasts.
- Als het netsnoer beschadigd is, moet dit worden vervangen door de fabrikant, een servicecentrum of een gekwalificeerd vakman om gevaren te voorkomen.
- Het apparaat kan worden gebruikt door kinderen vanaf 8 jaar en personen met verminderde fysieke, zintuiglijke of mentale vermogens of een gebrek aan ervaring en kennis, indien zij onder toezicht staan of instructies hebben gekregen over het veilige gebruik van het apparaat en als zij de gevaren ervan begrijpen. Kinderen mogen niet met het apparaat spelen. Reiniging of onderhoud mag niet door kinderen worden uitgevoerd, tenzij ze ouder zijn dan 8 jaar en onder toezicht staan.
- Houd het apparaat en het netsnoer buiten het bereik van kinderen jonger dan 8 jaar.
- Dit apparaat is niet bedoeld om te worden gebruikt met een externe timer of een afzonderlijke afstandsbediening.
- De oppervlakken van het apparaat kunnen tijdens gebruik heet worden.
- De deur of de buitenkant van het apparaat kan tijdens gebruik heet worden.
- Plaats het apparaat niet in of in de buurt van gaskachels of elektrische kachels of een verwarmde oven of mini-oven.







- Voor meer informatie over het reinigen van de oppervlakken die in contact komen met levensmiddelen, zie het hoofdstuk 'REINIGING EN ONDERHOUD' op pagina 21 van de gebruiksaanwijzing.
-  Voorzichtig: Heet oppervlak.
- De oppervlakken kunnen tijdens het gebruik heet worden.

## VEILIGHEIDSINFORMATIE

- Dompel het snoer, de stekker of een onderdeel van het apparaat niet onder in water of een andere vloeistof.
- Laat het netsnoer niet over de rand van een tafel hangen of in contact komen met hete oppervlakken.
- Als u de oven gebruikt, houd minstens 10 cm vrije ruimte langs alle zijden van de oven om voor voldoende luchtcirculatie te zorgen.
- Om het apparaat uit te schakelen, draai de functieregelaar naar de positie Uit en haal de stekker vervolgens uit het stopcontact.
- Haal de stekker uit het stopcontact wanneer u het apparaat niet gebruikt en voor reiniging. Houd het snoer altijd bij de stekker vast en trek nooit aan het snoer.
- Laat het apparaat volledig afkoelen alvorens onderdelen terug te plaatsen of te verwijderen en voor reiniging van het apparaat.
- Wees voorzichtig wanneer u een apparaat met hete olie of etenswaren verplaatst.
- Dek geen enkel onderdeel van de oven af met metaal of doek om oververhitting van de oven te vermijden.
- Plaats geen enkel voorwerp op de oven en dek de oven niet af.
- Wees zeer voorzichtig wanneer u de bakplaat uithaalt of het hete vet of een andere hete vloeistof weggiet.
- Laat dit apparaat niet zonder toezicht achter wanneer in werking.
- Plaats geen bovenmaats voedsel of metalen keukengerei in het apparaat om het risico op brand of een elektrische schok te vermijden.





- Wees zeer voorzichtig wanneer u kookgerei gebruikt dat niet van hoogwaardig metaal of keramiek is gemaakt.
- Plaats geen brandbare materialen in de oven zoals kunststof, papier of een soortgelijk materiaal.
- Gebruik alleen accessoires in deze oven die door de fabrikant zijn aanbevolen.
- Draag altijd beschermende, geïsoleerde ovenwanten als u voorwerpen in de oven plaatst of eruit haalt.
- Kinderen moeten onder toezicht staan om er zeker van te zijn dat ze niet met het apparaat spelen.
- Niet voor gebruik buitenshuis.
- Het product is uitsluitend bestemd voor huishoudelijk gebruik. Gebruik het apparaat alleen waarvoor het bestemd is.
- De glazen deur is zwaar. Houd de deur vast totdat deze volledig open is en laat de deur niet uit zichzelf vallen.





## PRODUCTOVERZICHT

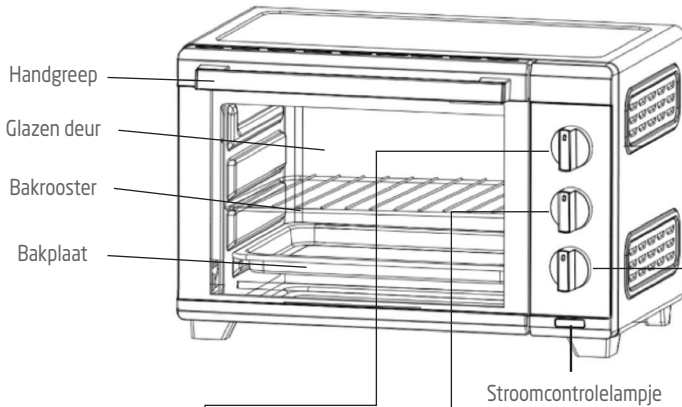

Temperatuurregelaar



Functieregelaar



Timerknop



### Bakplaat

Voor het braden en roosteren van vlees, gevogelte, vis en andere etenswaren en het opvangen van etensresten wanneer het als een lekbak wordt gebruikt.

Te gebruiken op de middelste of onderste ovenrails van het apparaat.

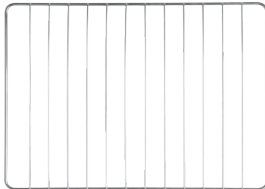

### Bakrooster

Voor het braden, bakken, roosteren en algemeen koken van etenswaren in kookgerei van metaal of ovensvast glas.

Te gebruiken op de bovenste, middelste of onderste ovenrails van het apparaat.

FR

NL

EN

ES

PT

17





## VOOR HET EERSTE GEBRUIK

Verwijder alle verpakkingsmateriaal.

Maak het bakrooster en de bakplaat schoon in een warm sopje. Spoel en veeg ze grondig droog



Maak de buitenkant van de oven schoon met een licht bevochtigde doek. Dompel het apparaat nooit onder in water.

## GEBRUIK

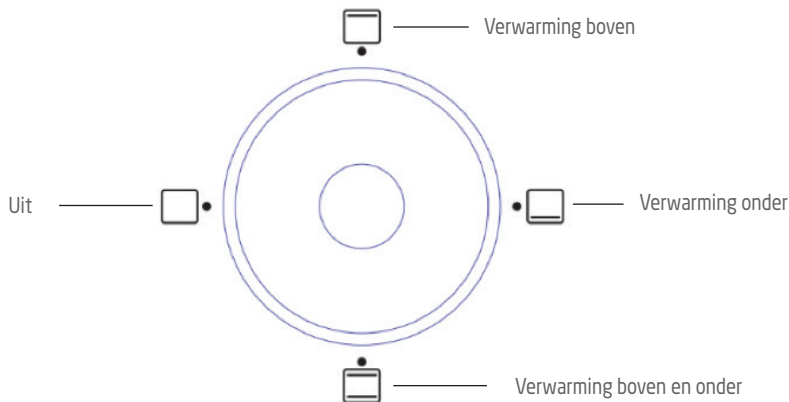
1. Plaats de oven op een schoon, vlak en hittebestendig oppervlak.
  - Zorg voor voldoende ventilatie rondom de oven.
  - Zorg dat de oven volledig droog is voordat u deze gebruikt.
  - Plaats de oven niet op een onbehandeld houten oppervlak.
2. Steek de stekker van de oven in het stopcontact.
3. Draai de temperatuurregelaar om een gewenste temperatuur tussen 100°C en 230°C in te stellen.
4. Draai de functieregelaar naar de gewenste positie.





	<p>Wanneer deze functie wordt gebruikt, worden alleen de bovenste verwarmingselementen gebruikt. Plaats de etenswaren op het bakrooster. Brenge het bakrooster op de bovenste ovenrails aan terwijl het bakrooster op de middelste ovenrails wordt aangebracht.</p>
	<p>Wanneer deze functie wordt gebruikt, worden alleen de onderste verwarmingselementen gebruikt. Plaats de etenswaren op het bakrooster of de bakplaat. Wanneer het bakrooster wordt gebruikt, brenge het op de middelste ovenrails aan terwijl de bakplaat op de onderste ovenrails wordt aangebracht, indien nodig.</p>
	<p>Wanneer deze functie wordt gebruikt, worden zowel de bovenste als de onderste verwarmingselementen gebruikt. Plaats de etenswaren op het bakrooster of de bakplaat. Wanneer het bakrooster wordt gebruikt, brenge het op de middelste ovenrails aan terwijl de bakplaat op de onderste ovenrails wordt aangebracht, indien nodig.</p>

5. Draai de timerknop naar de gewenste baktijd.

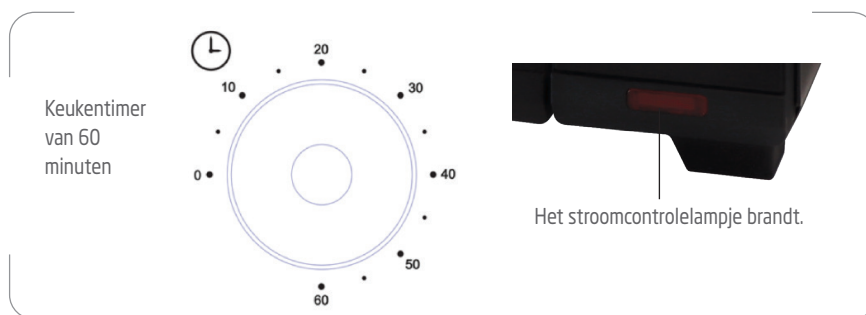

6. Zodra de baktijd is verstreken, hoort u een belgeluid om aan te geven dat het bakproces beëindigd is.

- Het stroomcontrolelampje dooft.
- U kunt de timerknop tevens voor het verstrijken van de ingestelde baktijd naar de positie 0 draaien om het bakproces te beëindigen.

**OPMERKING:**

- De oven kan een bepaalde geur en rook afgeven wanneer deze voor de eerste keer wordt gebruikt. Dit is normaal gezien overtollige oliën in de verwarmingselementen worden verbrand. De rook zal na 5 tot 10 minuten verdwijnen.

FR

NL

EN

ES

PT

19





- Voor betere bakprestaties wordt het aanbevolen om de oven 10 tot 15 minuten voor te verwarmen.

### Grillen

- Laat de deur open staan.
- Draai de functieregelaar naar de GRILL-instelling .
- Draai de temperatuurregelaar naar 230°C.
- Draai de timerknop naar de gewenste grilltijd.
- Na het grillen, draai de timerknop naar de positie 0 om de oven uit te schakelen.

### Na gebruik

Draai de timerknop opnieuw naar de positie 0.

Draai de functieregelaar naar de positie Uit.

Haal de stekker van de oven uit het stopcontact.

Wacht totdat de oven volledig is afgekoeld voordat u de oven schoonmaakt of onderhoudt.





## **REINIGING EN ONDERHOUD**

Trek de stekker uit het stopcontact en laat het apparaat afkoelen voordat u het schoonmaakt.

Dompel het apparaat niet in water. Maak alle oppervlakken schoon met een schone, vochtige doek.

Maak de binnenkant van de oven schoon met een schone, vochtige doek.

Maak het bakrooster en de bakplaat schoon in een warm sopje. Spoel en veeg ze grondig droog.

Gebruik nooit schurende of chemische reinigingsmiddelen.

Oppervlakken die in contact komen met voedsel moeten regelmatig worden schoongemaakt om kruisverontreiniging door verschillende soorten voedsel te voorkomen; het gebruik van een vochtige doek is aan te bevelen bij oppervlakken die in contact komen met voedsel.

Voer de juiste praktijken voor voedingshygiëne op elke moment uit om een mogelijke voedselvergiftiging of kruisverontreiniging te vermijden.

Veeg alle onderdelen en oppervlakken voor gebruik grondig droog.

Zorg dat alle onderdelen en oppervlakken volledig droog zijn voordat de stekker in het stopcontact wordt gestoken.

FR

NL

EN

ES

PT

21



## SPECIFICATIES

Voeding: 220-240V~ 50-60Hz  
1600 W

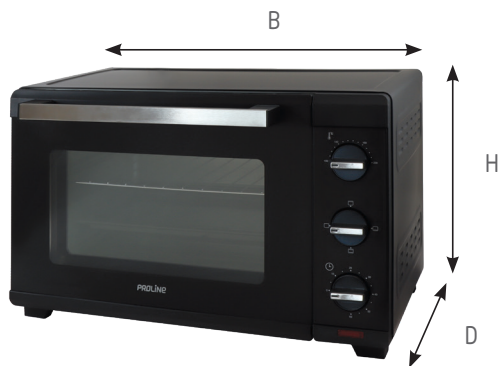

<b>Afmetingen (buitenafmetingen)</b>	(H) 325 x (B) 518 x (D) 378 mm
<b>Afmetingen (binnenafmetingen)</b>	(H) 270.2 x (B) 369 x (D) 291 mm
<b>Gewicht (ong.)</b>	7.3 kg





## VERWIJDERING



Als verantwoordelijke handelaar dragen we zorg voor het milieu. We moedigen u aan om de juiste verwijderingsprocedure voor uw apparaat en verpakkingsmateriaal te volgen. Dit draagt bij tot het behoud van de natuurlijke rijkdommen door deze te recyclen zodat zowel de menselijke gezondheid en het milieu worden beschermd.

Gooi dit apparaat en de verpakking weg in overeenstemming met de geldende wetgeving en voorschriften.

Aangezien dit apparaat elektronische componenten bevat moet het apparaat en toebehoren aan het einde van hun levensduur afzonderlijk van het huisafval worden weggegooid.

Neem contact op met uw gemeente voor informatie over afdanking en recycling. Lever het apparaat in bij het inzamelpunt van uw gemeente voor recycling. Bij sommige inzamelpunten kunt u het apparaat gratis inleveren.

### **Hotline Vanden Borre**

De dienst na verkoop is bereikbaar van maandag tot zaterdag op +32 2 334 00 00, maandag tot zaterdag van 08.00 tot 18.00 uur.

We verontschuldigen ons voor enig ongemak veroorzaakt door kleine inconsistenties in deze gebruikershandleiding, die kunnen ontstaan door productverbetering of -ontwikkeling.

Etablissements Darty & fils ©,  
9 Rue des Bateaux-Lavoires, 94200 Ivry-sur-Seine, France 08/04/2022

FR

NL

EN







ES

PT

23



# TABLE OF CONTENTS

-  **IMPORTANT SAFETY INSTRUCTIONS**..... p. 25
-  **PRODUCT OVERVIEW**..... p. 28
-  **BEFORE FIRST USE**..... p. 29
-  **OPERATION**..... p. 29
-  **CLEANING AND MAINTENANCE**..... p. 32
-  **SPECIFICATIONS** ..... p. 33
-  **DISPOSAL**..... p. 34





## **IMPORTANT SAFETY INSTRUCTIONS**

**PLEASE READ THE FOLLOWING SAFETY WARNINGS AND THE INSTRUCTIONS CAREFULLY BEFORE USING THE APPLIANCE AND KEEP FOR FUTURE REFERENCE.**

### **WARNINGS**

- This appliance is intended to be used in household and similar applications such as:
  - staff kitchen areas in shops, offices and other working environments;
  - farm houses;
  - by clients in hotels, motels and other residential type environments;
  - bed and breakfast type environments.
- If the supply cord is damaged, it must be replaced by the manufacturer, its service agent or similarly qualified persons in order to avoid a hazard.
- This appliance can be used by children aged from 8 years and above and persons with reduced physical, sensory or mental capabilities or lack of experience and knowledge if they have been given supervision or instruction concerning use of the appliance in a safe way and understand the hazards involved. Children shall not play with the appliance. Cleaning and user maintenance shall not be made by children unless they are older than 8 and supervised.
- Keep the appliance and its cord out of reach of children less than 8 years.
- The appliance is not intended to be operated by means of an external timer or separate remote-control system.
- The temperature of accessible surfaces may be high when the appliance is operating.
- The door or the outer surface may get hot when the appliance is operating.
- Do not place the appliance in or near hot gas or electric burner, or permit to touch a heated oven or mini oven.
- Regarding the instructions for cleaning surfaces in contact with

FR

NL

EN

ES

PT

25





food, refer to the section "CLEANING AND MAINTENANCE" on page 32 of the manual.

-  Caution: Hot Surface.  
The surfaces are liable to get hot during use.

## SAFETY INFORMATION

- Do not immerse cord, plug, or any part of the appliance in water or other liquids.
- Do not let cord hang over edge of table or counter, or touch hot surfaces.
- When operating the oven, keep at least 10 cm of space on all sides of the oven to allow for adequate air circulation.
- To disconnect, turn the function control knob to the Off position, before removing the plug.
- Unplug from the mains socket when not in use and before cleaning. Always hold the plug, but never pull the cord.
- Allow the appliance to cool before putting on or taking off parts, and before cleaning.
- Extreme caution must be used when moving an appliance containing hot oil or food.
- Do not cover any part of the oven with metal or cloth, it may cause overheating of the oven.
- Do not place any item on the oven or cover the oven.
- Use extreme caution when removing tray or disposing of hot grease or other hot liquids.
- Do not leave the appliance unattended when in operation.
- Oversized foods or metal utensils cannot be put into the appliance as they may create a fire or risk of electric shock.
- Extreme caution should be exercised when using containers constructed of anything other than qualified metal or qualified ceramics.
- Do not place any of the following materials in the oven: plastic, paper, or anything similar.



- Do not use any accessories other than manufacturer recommended accessories in this oven.
- Always wear protective, insulated oven gloves when inserting or removing items from the hot oven.
- Children should be supervised to ensure that they do not play with the appliance.
- Do not use outdoors.
- The appliance is for household use only. Do not use the appliance for anything other than its intended use.
- The glass door is heavy, please hold the handle until the door is completely open, do not let the door fall itself.



FR

NL

EN

ES

PT

27





## PRODUCT OVERVIEW

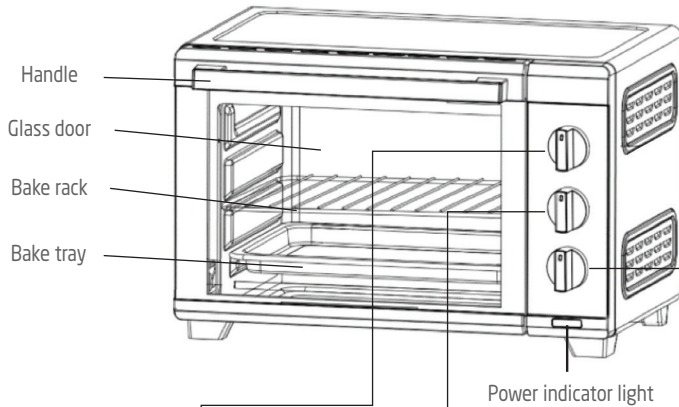

Temperature control knob



Function control knob



Timer control knob



### Baking tray

For broiling and roasting meat, poultry, fish and various other foods as well as collection food residues when used as a drip tray.

Use on the middle and bottom oven rails of the appliance.

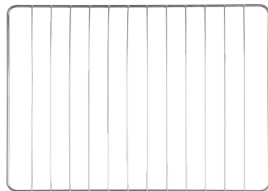

### Baking rack

For broiling, baking, toasting and general cooking with other containers made of metal or ovenproof glass.

Use on the top, middle and bottom oven rails of the appliance.





## BEFORE FIRST USE

Remove all packaging materials.

Wash the bake rack and bake tray in warm soapy water. Rinse and dry thoroughly.

Wipe the outside of oven with a slightly damp cloth. Never immerse the appliance in water.

## OPERATION

1. Place the oven on a clean, flat and heat resistant surface.
  - Ensure that there is enough ventilation around the oven.
  - Ensure that the oven is completely dry before use.
  - The oven should not be placed on untreated wooden surface.
2. Plug in the oven.
3. Turn the temperature control knob to the desired temperature from 100°C to 230°C.
4. Turn the function control knob to the desired position.

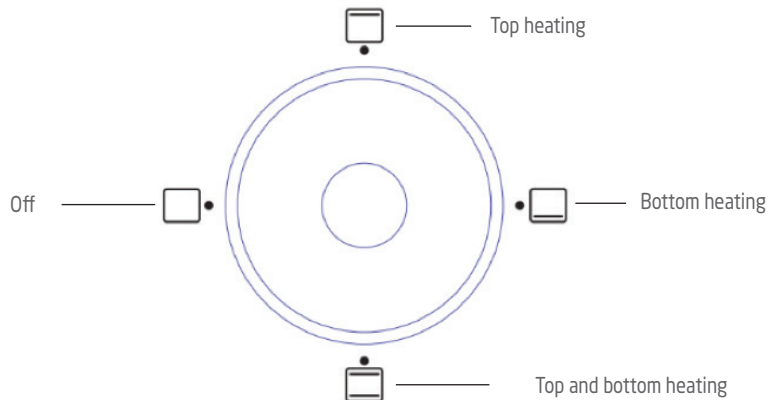

FR

NL

EN



ES

PT

29





	<p>When using this function, only the top heating elements are being used. Place the food on the baking rack. Place the baking rack on the top oven rails while the baking tray is placed on the middle oven rails.</p>
	<p>When using this function, only the bottom heating elements are being used. Place the food on the baking rack or baking tray. When using the baking rack, place the baking rack on the middle oven rails while the baking tray is placed on the bottom oven rails, if necessary.</p>
	<p>When using this function, the top and bottom heating elements are being used. Place the food on the baking rack or baking tray. When using the baking rack, place the baking rack on the middle oven rails while the baking tray is placed on the bottom oven rails, if necessary.</p>

5. Turn the timer control knob to the desired cooking time.

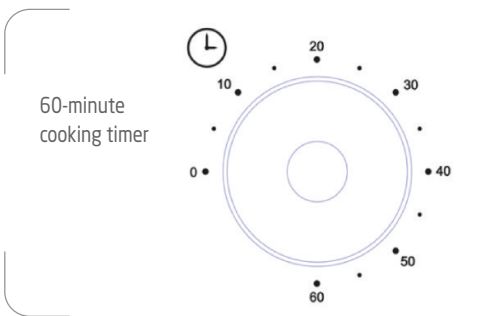

60-minute  
cooking timer



The power indicator light will  
illuminate.

6. When the cooking time has elapsed, a bell will ring to indicate the cooking cycle has finished.

- The power indicator light will go out.
- Before the set cooking time has been reached, you can turn the timer control knob to the 0 position to finish cooking.

**NOTE:**

- When using the oven for the first time, the oven may produce an odor and emit smoke. The oven is burning off the excess oils in the heating elements and this is normal. After 5 to 10 minutes the smoke will disappear.
- In order to get better cooking performance, it is recommended to pre-heat the oven for 10 to 15 minutes.







### Grill cooking

- Leave the door at the open point.
- Turn the function control knob to GRILL setting .
- Turn the temperature control knob to 230°C.
- Turn the timer control knob to the desired grill time.
- When the grill cooking is done, turn the timer control knob to the 0 position to turn off the oven.

### After use

Turn back the timer control knob to the 0 position.

Turn the function control knob to the Off position.

Unplug the oven from the mains socket.

Wait until the oven is completely cool before carrying out any cleaning or maintenance





## **CLEANING AND MAINTENANCE**

Unplug the appliance and allow it to cool before cleaning.

Do not immerse the appliance in water. All surfaces can be cleaned with a clean damp cloth.

Clean the interior chamber with a clean damp cloth.

Wash the bake rack and bake tray in warm soapy water. Rinse and dry thoroughly.

Never use abrasive or chemical cleaning agents.

Surfaces in contact with food should be cleaned regularly to avoid cross contamination from different types of food, the use of a damp cloth is advisable when dealing with surfaces that come into contact with food.

Correct food hygiene practices should always be followed at all times to avoid possibility of food poisoning /cross contamination.

Dry all parts and surfaces thoroughly before use.

Make sure that all parts and surfaces are completely dry before plugging in the appliance.





## SPECIFICATIONS

Ratings: 220-240V~ 50-60Hz  
1600 W



<b>Dimensions (outer dimensions)</b>	(H) 325 x (W) 518 x (D) 378 mm
<b>Dimensions (cavity / inner dimensions)</b>	(H) 270.2 x (W) 369 x (D) 291 mm
<b>Weight (approx.)</b>	7.3 kg

FR

NL

EN

ES

PT

33



## DISPOSAL



As a responsible retailer we care about the environment. As such we urge you to follow the correct disposal procedure for the appliance and packaging materials. This will help conserve natural resources and ensure that it is recycled in a manner that protects health and the environment.

You must dispose of this appliance and its packaging according to local laws and regulations.

Because this appliance contains electronic components, the appliance and its accessories must be disposed of separately from household waste when the appliance reaches its end of life.

Contact your local authority to learn about disposal and recycling.

The appliance should be taken to your local collection point for recycling. Some collection points accept appliance free of charge.

We apologise for any inconvenience caused by minor inconsistencies in these instructions, which may occur as a result of product improvement and development.







Etablissements Darty & fils ©,

9 Rue des Bateaux-Lavois, 94200 Ivry-sur-Seine, France 08/04/2022





# ÍNDICE

-  **MEDIDAS DE SEGURIDAD IMPORTANTES.....** p. 36
-  **DESCRIPCIÓN DEL PRODUCTO.....** p. 39
-  **ANTES DE USAR POR PRIMERA VEZ.....** p. 40
-  **MODO DE EMPLEO .....** p. 40
-  **LIMPIEZA Y MANTENIMIENTO.....** p. 43
-  **ESPECIFICACIONES.....** p. 44
-  **ELIMINACIÓN.....** p. 45



FR

NL

EN

**ES**

PT

35





## **⚠ MEDIDAS DE SEGURIDAD IMPORTANTES**

**LEA DETENIDAMENTE ESTAS INSTRUCCIONES Y MEDIDAS DE SEGURIDAD ANTES DE USAR EL APARATO Y GUÁRDELAS PARA FUTURAS CONSULTAS.**

### **ADVERTENCIAS**

- Este aparato ha sido diseñado para utilizarse en aplicaciones domésticas y similares, tales como:
  - Cocinas para el personal en tiendas, oficinas y otros entornos laborales.
  - Casas rurales.
  - Para uso de la clientela en hoteles, hostales y otros entornos de tipo residencial.
  - Establecimientos de tipo cama y desayuno.
- Si el cable de alimentación se daña, deberá reemplazarlo el fabricante, su agente de servicios, o alguna persona con una cualificación similar con el fin de evitar situaciones de peligro.
- Este aparato puede ser utilizado por niños a partir de los 8 años y por personas con minusvalías físicas, sensoriales o mentales, o que no cuenten con la experiencia y los conocimientos necesarios, siempre que estén supervisados o hayan sido instruidos sobre el uso seguro del aparato y entiendan los peligros que conlleva. No permita que los niños jueguen con el aparato. Las tareas de limpieza y mantenimiento a cargo del usuario no podrán ser realizadas por niños, salvo que sean mayores de 8 años y estén supervisados.
- Mantenga el aparato y su cable fuera del alcance de los niños menores de 8 años.
- Este aparato no ha sido diseñado para ser utilizado de forma conjunta con un temporizador externo o un sistema de control a distancia independiente.
- Las superficies accesibles del aparato pueden alcanzar temperaturas elevadas cuando está en funcionamiento.
- La puerta y la superficie externa pueden alcanzar temperaturas elevadas cuando el aparato está en funcionamiento.
- No coloque el aparato sobre o cerca de quemadores de gas o





eléctricos calientes, ni permita que entre en contacto con un horno o minihorno caliente.

- La información sobre la limpieza de las superficies en contacto con los alimentos se encuentra en el apartado Limpieza y mantenimiento de la página 43 del manual.



- **Atención superficie caliente.**  
Las superficies del aparato pueden calentarse durante su uso.

### **INFORMACIÓN SOBRE SEGURIDAD**

- No sumerja el cable, el enchufe o alguna otra parte del aparato en agua u otros líquidos.
- No deje el cable colgando por el borde de la mesa o la encimera ni en contacto con superficies calientes.
- Cuando utilice el horno, mantenga un espacio de al menos 10 cm en todos los lados del horno para permitir una adecuada circulación del aire.
- Para desenchufarlo, gire primero el mando de funciones a la posición de apagado y retire entonces el enchufe.
- Desenchufe siempre el aparato de la toma de corriente cuando no esté en uso o antes de limpiarlo. Tire siempre directamente del enchufe, nunca del cable.
- Deje que el aparato se enfríe antes de colocar o quitar piezas o antes de limpiarlo.
- Tenga mucho cuidado al mover el aparato cuando contenga aceite o comida caliente.
- No cubra ninguna parte del horno con paños o artículos metálicos, dado que podría sobrecalentar el horno.
- No cubra el horno ni coloque artículos encima.
- Tenga mucho cuidado cuando saque la bandeja o deseche la grasa caliente u otros jugos calientes.
- No deje el aparato desatendido cuando esté funcionando.
- No se deben introducir en el aparato utensilios de metal o alimentos de gran tamaño, dado que podrían causar un incendio

FR

NL

EN

**ES**

PT

37



o choques eléctricos.

- Tenga mucho cuidado cuando use recipientes fabricados con materiales que no sean de metal o cerámica aptos para hornos.
- No coloque ninguno de los siguientes materiales dentro del horno: plástico, papel o materiales similares.
- No guarde ningún material en este horno cuando no se esté utilizando, salvo los accesorios recomendados por el fabricante.
- Utilice siempre guantes de protección aislantes para horno cuando introduzca o retire artículos del horno caliente.
- Se debe vigilar a los niños para asegurarse de que no juegan con el aparato.
- No utilice en exteriores.
- Este aparato solo es apto para uso doméstico. No utilice este aparato para fines distintos al previsto.
- La puerta de vidrio es pesada. Por favor, sujétela del asa hasta que la haya abierto del todo; no la deje caer por su propio peso.







## DESCRIPCIÓN DEL PRODUCTO

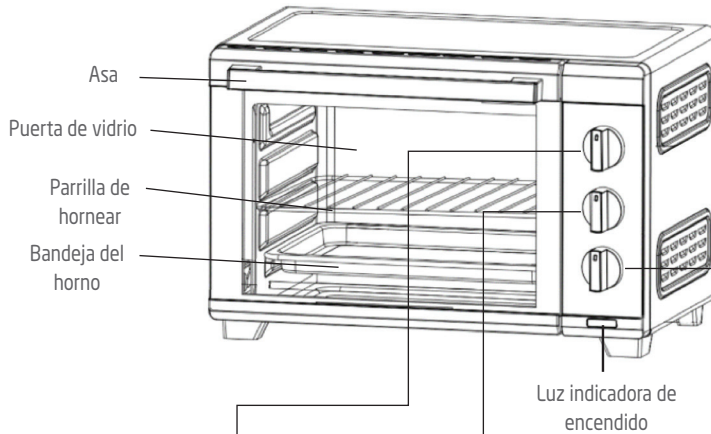

Mando regulador de temperatura

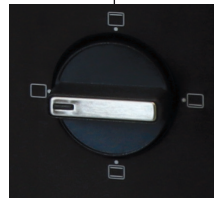

Mando de funciones



Mando del temporizador



### Bandeja de hornear

Para asar o rostizar carnes, aves, pescado u otros alimentos, así como recoger restos de alimentos cuando se utiliza como una bandeja recogejugos.

Utilice los carriles inferiores o medios del aparato.

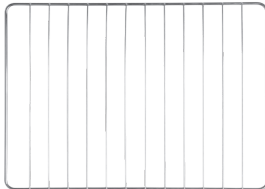

### Parrilla de hornear

Para asar, hornear, tostar y cocinar en general con otros recipientes de metal o vidrio aptos para hornos.

Utilice en los carriles inferiores, medios o superiores del aparato.

FR

NL

EN

ES

PT

39





## ANTES DE USAR POR PRIMERA VEZ

Retire todo el material de embalaje.

Lave la parrilla y la bandeja en agua jabonosa tibia, enjuáguelas y séquelas bien.



Limpie el exterior del horno con un paño un poco húmedo. No sumerja nunca el aparato en el agua.

## MODO DE EMPLEO

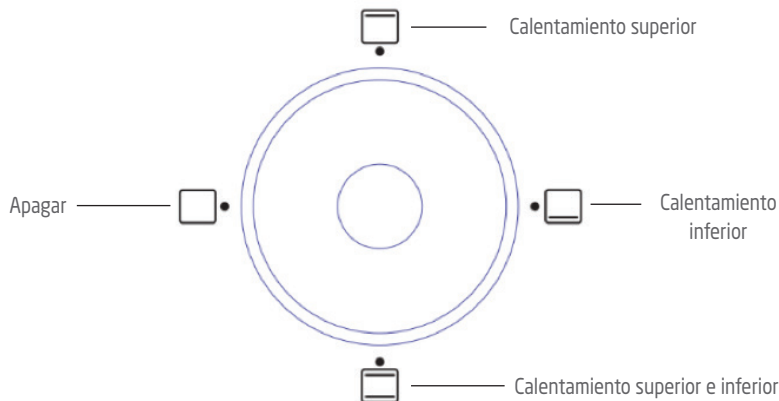
1. Coloque el horno sobre una superficie plana, limpia y resistente al calor.
  - Asegúrese de que haya suficiente ventilación alrededor del horno.
  - Asegúrese de que el horno esté completamente seco antes de utilizarlo.
  - El horno no debe colocarse sobre una superficie de madera sin tratar.
2. Enchufe el horno.
3. Gire el mando de la temperatura hasta la temperatura deseada, entre 100 °C y 230 °C.
4. Gire el mando de funciones a la posición deseada.





	En esta función, sólo se utilizan las resistencias superiores. Coloque la comida en la parrilla. Inserte la parrilla por los carriles superiores del horno y la bandeja en los carriles medios.
	En esta función, sólo se utilizan las resistencias inferiores. Coloque la comida en la parrilla o en la bandeja de hornear. Cuando utilice la parrilla, colóquela en los carriles del medio y, si fuera necesario, coloque la bandeja de hornear en los carriles inferiores del horno.
	En esta función, se utilizan las resistencias superior e inferior. Coloque la comida en la bandeja de hornear o en la parrilla. Cuando utilice la parrilla, colóquela en los carriles del medio y, si fuera necesario, coloque la bandeja de hornear en los carriles inferiores del horno.

5. Gire el mando del temporizador al tiempo de cocción requerido.

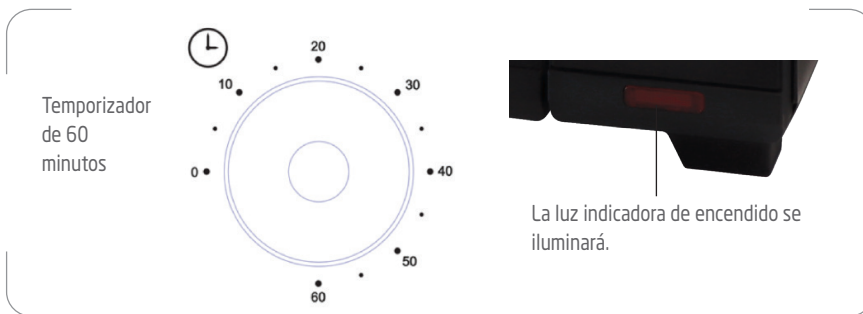

6. Una vez transcurrido el tiempo de cocción, se escuchará un timbre para indicar que el ciclo de cocción ha finalizado.

- El indicador luminoso de alimentación se apagará.
- Antes de que se alcance el tiempo de cocción establecido, puede girar el mando del temporizador a la posición 0 para finalizar la cocción.

**NOTA:**

- Cuando utilice el horno por primera vez, puede que desprenda olor y humo al quemarse el exceso de aceites en las resistencias. Esto es algo normal y el humo desaparecerá tras 5 o 10 minutos.
- Para una cocción más efectiva, se recomienda precalentar el horno de 10 a 15 minutos.





### **Cocción a la parrilla**

- Deje la puerta abierta.
- Gire el mando de funciones a la posición de cocción a la parrilla .
- Gire el mando de la temperatura a 230 °C.
- Gire el mando del temporizador hasta el tiempo de cocción a la parrilla deseado.
- Una vez finalizada la cocción a la parrilla, gire el mando del temporizador a la posición 0 para apagar el horno.

### **Después de usar**

Gire el mando del temporizador a la posición 0.

Gire mando de funciones a la posición de apagado.

Desenchufe el horno de la toma de corriente.

Espere a que el horno se haya enfriado del todo antes de llevar a cabo alguna tarea de limpieza o mantenimiento.





## LIMPIEZA Y MANTENIMIENTO

Desenchufe el aparato y espere a que se enfríe antes de limpiarlo.

No sumerja el aparato en el agua. Todas las superficies pueden limpiarse con un paño limpio y húmedo.

Limpie el interior con un paño limpio y húmedo.

Lave la parrilla y la bandeja de hornear en agua jabonosa tibia. Enjuague y seque bien.

No utilice nunca productos de limpieza químicos o abrasivos.

Las superficies en contacto con los alimentos deben limpiarse regularmente para evitar la contaminación cruzada entre los distintos tipos de alimentos. Se recomienda usar un paño suave y húmedo para limpiar las superficies que hayan entrado en contacto con los alimentos.

Siempre se debe practicar una buena higiene al manipular alimentos para evitar intoxicaciones alimentarias o una contaminación cruzada de alimentos.

Seque bien todas las superficies antes de usar.

Asegúrese de que todas las superficies del aparato se hayan secado por completo antes de enchufarlo.

FR

NL

EN

ES

PT

43



## **ESPECIFICACIONES**

Datos nominales: 220-240V~ 50-60Hz  
1600 W



<b>Dimensiones (dimensiones exteriores)</b>	(Al) 325 x (An) 518 x (Pr) 378 mm
<b>Dimensiones (dimensiones interiores / cavidad)</b>	(Al) 270.2 x (An) 369 x (Pr) 291 mm
<b>Peso (aprox.)</b>	7.3 kg



## ELIMINACIÓN



Somos un distribuidor responsable y nos preocupa el medio ambiente. Por estemotivo le pedimos que siga correctamente las instrucciones de eliminación a la hora de desechar el aparato y su material de embalaje. De estemodo, contribuirá a la conservación de los recursos naturales y garantizará que se recicla de modo correcto para preservar la salud las personas y el medio ambiente.

Este aparato y su embalaje se deben desechar conforme a la normativa y regulación local.

Debido a que el aparato contiene componentes electrónicos, el aparato y sus accesorios no se deben tirar en la basura doméstica al final de la vida útil del aparato.

Consulte a las autoridades locales sobre el modo correcto de eliminación y reciclaje de residuos.

El aparato se debe depositar en un punto local de recogida de residuos para proceder a su reciclaje. En algunos puntos de recogida se aceptan residuos gratuitamente.

Le pedimos disculpas por cualquier problema provocado por pequeñas inconsistencias en estas instrucciones, que podrían ser debidas al proceso de desarrollo y mejora del producto.



Solo para España

Etablissements Darty & fils ©,  
9 Rue des Bateaux-Lavoirs, 94200 Ivry-sur-Seine, France 08/04/2022

FR

NL

EN

ES







PT

45





# ÍNDICE

	INSTRUÇÕES DE SEGURANÇA IMPORTANTE.....	p. 47
	VISTA PORMENORIZADA DO PRODUTO.....	p. 50
	ANTES DA PRIMEIRA UTILIZAÇÃO.....	p. 51
	FUNIONAMENTO.....	p. 51
	LIMPEZA E MANUTENÇÃO.....	p. 54
	CARACTERÍSTICAS TÉCNICAS .....	p. 55
	ELIMINAÇÃO.....	p. 56







## **⚠ INSTRUÇÕES DE SEGURANÇA IMPORTANTES**

**LEIA OS SEGUINTE AVISOS DE SEGURANÇA E AS INSTRUÇÕES CUIDADOSAMENTE ANTES DE UTILIZAR O APARELHO E GUARDE PARA FUTURAS REFERÊNCIAS.**

### **AVISOS**

- Este aparelho foi criado para ser usado em aplicações domésticas e semelhantes, como:
  - Áreas de cozinha do pessoal em lojas, escritórios e outros ambientes de trabalho;
  - Casas de campo;
  - Por clientes em hotéis, motéis e outros ambientes do tipo residencial;
  - Ambientes do tipo residenciais com pequeno-almoço.
- Se o fio da alimentação ficar danificado, deverá ser substituído pelo fabricante, o agente de reparação ou uma pessoa igualmente qualificada, de modo a evitar quaisquer perigos.
- Este aparelho pode ser utilizado por crianças com idade a partir dos 8 anos e pessoas com capacidades físicas, sensoriais ou mentais reduzidas ou falta de experiência e conhecimento se forem supervisionadas ou se tiverem recebido instruções relativamente à utilização do aparelho de uma forma segura e compreendem os riscos envolvidos.  
As crianças não devem brincar com o aparelho.  
A limpeza e a manutenção não devem ser realizadas por crianças, exceto se tiverem mais de 8 anos e forem supervisionadas.
- Mantenha o aparelho e o fio fora do alcance de crianças com menos de 8 anos.
- Este aparelho não foi criado para ser utilizado com um temporizador externo ou um sistema de comando à distância em separado.
- A temperatura das superfícies acessíveis pode ser alta quando o aparelho está a funcionar.
- A porta da superfície externa pode aquecer quando o aparelho estiver a funcionar.
- Não coloque o aparelho em cima ou perto de um fogão a gás ou

FR

NL

EN

ES

**PT**

47





elétrico que esteja quente, nem permita que toque num forno ou mini-forno aquecido.

- Relativamente às instruções de limpeza das superfícies em contacto com os alimentos, consulte a secção "LIMPEZA E MANUTENÇÃO" na página 54 do manual.



- Cuidado: Superfície quente.
- As superfícies podem ficar quentes durante a utilização.

### Informação de segurança

- Não mergulhe o fio, ficha nem qualquer outra parte do aparelho em água ou noutros líquidos.
- Não deixe o fio pender de uma mesa ou bancada nem entrar em contacto com superfícies quentes.
- Quando utilizar o forno, mantenha, pelo menos, 10 cm de espaço em redor, para permitir uma circulação adequada do ar.
- Para desligar, rode o manípulo de controlo da função para a posição de desligado antes de retirar a ficha da tomada.
- Retire a ficha da tomada quando não utilizar o aparelho e antes de proceder à limpeza. Puxe sempre pela ficha e não pelo fio.
- Deixe que este arrefeça antes de colocar ou retirar peças, e antes de limpar o aparelho.
- Deve ter muito cuidado quando mover um aparelho que contenha óleo quente ou alimentos.
- Não cubra nenhuma parte do forno com metal ou panos. Isso pode causar um sobreaquecimento do forno.
- Não coloque artigos em cima do forno nem cubra o forno.
- Tenha muito cuidado quando retirar a bandeja ou eliminar gordura quente ou outros líquidos quentes.
- Não deixe o aparelho sem supervisão durante o funcionamento.
- Não coloque alimentos demasiado grandes nem utensílios de metal dentro do aparelho, pois estes podem criar fogo ou risco de choque elétrico.
- Tenha muito cuidado quando usar recipientes com outros





- materiais sem ser metal ou cerâmica.
- Não coloque nenhum dos seguintes materiais dentro do forno: plástico, papel ou algo semelhante.
  - Não use qualquer acessório para além dos recomendados pelo fabricante.
  - Use sempre luvas de proteção para o forno quando inserir ou retirar artigos do forno quente.
  - As crianças devem ser supervisionadas, para se certificar de que não brincam com o aparelho.
  - Não use no exterior.
  - O aparelho destina-se apenas a uso doméstico. Não use o aparelho para outros fins para além daqueles para que foi previsto.
  - A porta de vidro é pesada. Segure a pega até que a porta seja completamente aberta. Não deixe a porta descer sozinha.



FR

NL

EN

ES

PT

49





## VISTA PORMENORIZADA DO PRODUTO

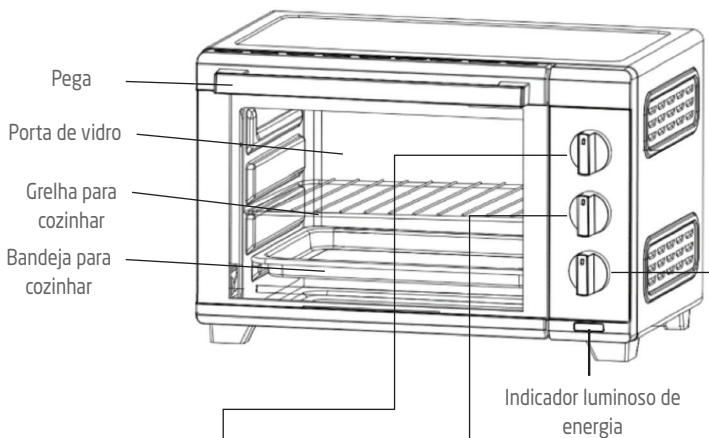

Manípulo de controlo da temperatura



Manípulo de controlo da função



Manípulo de controlo do temporizador



### Bandeja para cozinhar

Para grelhar e assar carne, aves, peixe e muitos outros alimentos, bem como para recolher resíduos de alimentos quando usada como bandeja dos pingos. Use as calhas do forno intermédias e inferiores.

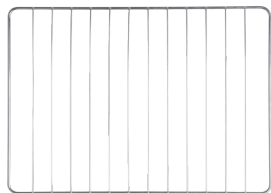

### Grelha para cozinhar

Para grelhar, cozer, torrar e cozinhar de forma geral com outros recipientes de metal ou de vidro adequado para o forno. Use as calhas do forno superiores, intermédias e inferiores.





## **ANTES DA PRIMEIRA UTILIZAÇÃO**

Retire todo o material de empacotamento.

Lave a grelha para cozinhar e a bandeja para cozinhar com água quente e detergente. Passe por água e seque bem.

Limpe a superfície externa do forno com um pano ligeiramente embebido em água. Nunca coloque o aparelho dentro de água.

## **FUNCIONAMENTO**

1. Coloque o forno numa superfície limpa, plana e resistente ao calor.
  - Certifique-se de que há ventilação suficiente em redor do forno.
  - Certifique-se de que o forno está completamente seco antes da utilização.
  - O forno não deverá ser colocado numa superfície de madeira não tratada.
  - Plug in the oven.
2. Ligue o forno à alimentação.
3. Rode o manípulo de controlo da temperatura para a temperatura desejada, de 100 °C a 230 °C.
4. Rode o manípulo de controlo da função para a posição desejada.

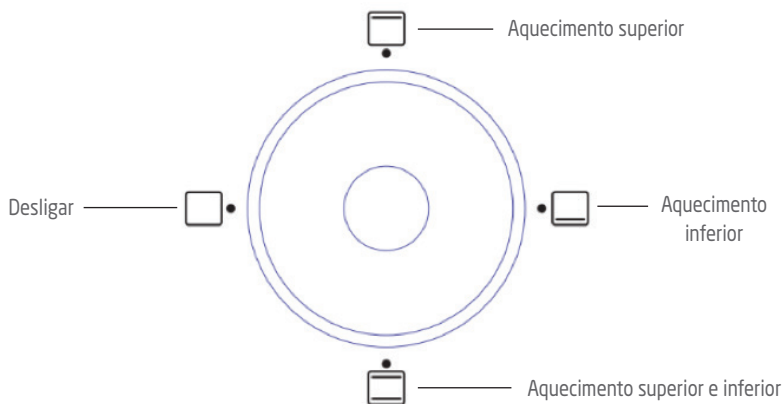

FR

NL

EN

ES

PT

51



	<p>Quando usar esta função, apenas os elementos de aquecimento superiores são usados. Coloque os alimentos na grelha para cozinhar. Coloque a grelha para cozinhar nas calhas superiores do forno, enquanto a bandeja para cozinhar é colocada nas calhas intermédias do forno.</p>
	<p>Quando usar esta função, apenas os elementos de aquecimento inferiores são usados. Coloque os alimentos na grelha para cozinhar ou bandeja para cozinhar. Quando usar a grelha para cozinhar, coloque-a nas calhas intermédias do forno, enquanto a bandeja para cozinhar é colocada nas calhas inferiores do forno, se necessário.</p>
	<p>Quando usar esta função, apenas os elementos de aquecimento superiores e inferiores são usados. Coloque os alimentos na grelha para cozinhar ou bandeja para cozinhar. Quando usar a grelha para cozinhar, coloque-a nas calhas intermédias do forno, enquanto a bandeja para cozinhar é colocada nas calhas inferiores do forno, se necessário.</p>

5. Rode o manípulo de controlo do temporizador para o tempo de cozedura desejado.

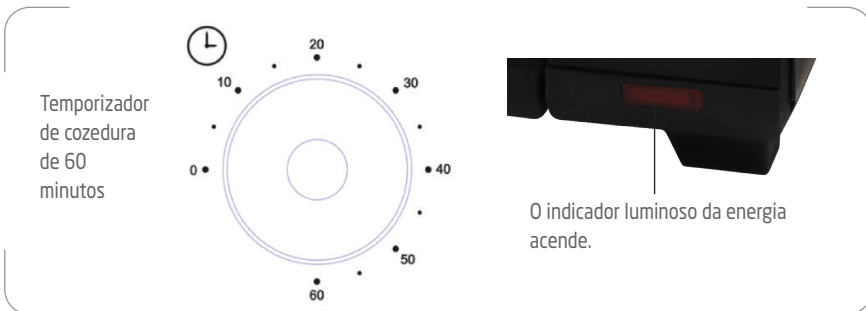

6. Quando o tempo de cozedura terminar, ouvirá uma campainha a indicar que o ciclo de cozedura terminou.
  - O indicador luminoso irá apagar-se.
  - Antes de o tempo de cozedura definido terminar, pode rodar o manípulo de controlo do temporizador para a posição 0 para terminar de cozinhar.

**NOTA:**

- Quando usar o forno pela primeira vez, pode notar num ligeiro odor e emissão de fumo. O forno está a queimar o excesso de óleo nos elementos





de aquecimento. Isto é normal. Passados 5 a 10 minutos, o fumo desaparece.

- Para obter uma melhor cozedura, recomendamos que pré-aqueça o forno durante 10 a 15 minutos.

### **Cozinhar com grill**

- Deixe a porta aberta.
- Rode o manípulo de controlo da função para a posição GRILL .
- Rode o manípulo de controlo da temperatura para 230 °C.
- Rode o manípulo de controlo do temporizador para o tempo de grelhar desejado.
- Quando terminar de cozinhar com grill, rode o manípulo de controlo do temporizador para a posição 0 para desligar o forno.

### **Após a utilização**

Volte a rodar o manípulo de controlo do temporizador para a posição 0.

Rode o manípulo de controlo da função para a posição de desligado.

Desligue o forno da alimentação.

Esperre até que o forno arrefeça por completo antes de efetuar qualquer limpeza ou manutenção.



## LIMPEZA E MANUTENÇÃO

Desligue o aparelho da alimentação e deixe-o arrefecer antes de limpar.

Não coloque o aparelho dentro de água. Todas as superfícies podem ser limpas com um pano ligeiramente embebido em água.

Limpe a câmara interior com um pano limpo, ligeiramente embebido em água.

Lave a grelha para cozinhar e a bandeja para cozinhar com água quente e detergente. Passe por água e seque bem.

Nunca use agentes de limpeza abrasivos ou químicos.

As superfícies que entrem em contacto com alimentos devem ser limpas regularmente, para evitar a contaminação cruzada por tipos diferentes de alimentos. Aconselha-se o uso de um pano ligeiramente embebido em água para cuidar dessas superfícies.

Devem ser sempre seguidas práticas de higiene alimentar corretas, para evitar o risco de envenenamento alimentar/contaminação cruzada.

Seque bem todas as partes e superfícies antes da utilização.

Certifique-se de que todas as partes e superfícies estão completamente secas antes de ligar o aparelho à alimentação.





## **CARACTERÍSTICAS TÉCNICAS**

Especificações: 220-240V~ 50-60Hz  
1600 W



<b>Dimensões (dimensões exteriores)</b>	(A) 325 x (C) 518 x (P) 378 mm
<b>Dimensões (dimensões da cavidade / interior)</b>	(A) 270.2 x (C) 369 x (P) 291 mm
<b>Peso (aproximado)</b>	7.3 kg

FR

NL

EN

ES

**PT**

55



## ELIMINAÇÃO



Como retalhista responsável, preocupamo-nos com o ambiente. Como tal, aconselhamos que cumpra os procedimentos adequados para eliminação do aparelho e dos respectivos materiais de embalagem. Dessa forma, irá ajudar a conservar recursos naturais e assegurar que são reciclados de uma forma que protege a saúde e o ambiente.

Deve eliminar este aparelho e a sua embalagem de acordo com a legislação e regulamentação locais.

Dado que este aparelho contém componentes eletrónicos, o produto e os seus acessórios devem ser eliminados separadamente do lixo doméstico quando atingirem o fim da sua vida útil.

Contacte as autoridades locais para obter informações acerca da eliminação e reciclagem.

O aparelho deve ser transportado para o ponto de recolha local, para reciclagem. Alguns pontos de recolha aceitamos aparelhos sem cargas.

Pedimos desculpa por qualquer inconveniente provocado por pequenas inconsistências nestas instruções, as quais poderão ser resultado de melhoria e desenvolvimento do produto.

Etablissements Darty & fils ©,

9 Rue des Bateaux-Lavoirs, 94200 Ivry-sur-Seine, France 08/04/2022





# FNAC DARTY

Etablissements Darty & fils ©,  
9 Rue des Bateaux-Lavoirs,  
94200 Ivry-sur-Seine, France

## Déclaration UE de Conformité N°862022042579

*EU Declaration of Conformity*  
*EU- Conformiteitsverklaring*  
*Declaración UE de Conformidad*  
*Declaração UE de Conformidade*

### Description du produit –

FOUR POSABLE

*Product Description:*  
*Productbeschrijving:*  
*Descripción del producto:*  
*Descrição do produto:*

MINI OVEN  
VRIJSTAANDE OVEN  
HORNO INSTALABLE  
FORNO DE INSTALAÇÃO LIVRE



### Marque –

*Brand /Merk /Marca:*

Proline

### Référence commerciale –

*Model number:*  
*/Modelnummer / Numero de modelo /*  
*Numero do modelo:*

PMO30

### L'objet de la déclaration décrit ci-dessus est conforme à la législation d'harmonisation de l'Union applicable :

*The object of the declaration described above is in conformity with the relevant Union harmonisation legislation:*

*Het hierboven beschreven voorwerp is in overeenstemming met de desbetreffende harmonisatiewetgeving van de Unie:*

*El objeto de la declaración descrita anteriormente es conforme con la legislación de armonización pertinente de la Unión:*

*O objeto da declaração acima descrito está em conformidade com a legislação de harmonização da União aplicável:*





Reference number	Title
<input checked="" type="checkbox"/> 2014/30/EU	EMC Directive (EMC)
<input checked="" type="checkbox"/> 2014/35/EU	Low Voltage Directive (LVD)
<input checked="" type="checkbox"/> 2009/125/EC	Eco design requirements for energy-related products (ErP)
<input checked="" type="checkbox"/> 2011/65/EU & (EU) 2015/863	RoHS

**EMC:**  
EN 55014-1:2017  
EN 55014-2:2015  
EN IEC 61000-3-2:2019  
EN 61000-3-3:2013+A1:2019

**LVD :**  
EN 60335-2-9:2003+A1:2004+A2:2006+A12:2007+A13:2010  
EN 60335-1:2012+A11:2014+A13:2017+A1:2019+A14:2019+A2:2019  
EN 62233:2008

**ErP :**  
  
(EC) No 1275/2008  
(EU) No 801/2013  
(EU) 2016/2282  
EN 50564:2011

**La présente déclaration de conformité est établie sous la seule responsabilité du fabricant.**  
This declaration of conformity is drawn up under the sole responsibility of the manufacturer.  
Deze conformiteitsverklaring wordt uitsluitend onder de verantwoordelijkheid afgelegd van de fabrikant.  
Esta declaración de conformidad se redacta bajo la exclusiva responsabilidad del fabricante.  
Esta declaração de conformidade é redigida sob a responsabilidade exclusiva do fabricante.

**Le responsable de cette déclaration est :**  
The person responsible for this declaration is:  
De verantwoordelijke persoon voor deze verklaring is:  
La persona responsable de esta declaración es:  
A pessoa responsável por esta declaração é:

Signé par et au nom de – Signed by and on behalf of: **Etablissements Darty & Fils**  
Nom – Name : **Predrag Petricevic**  
Fonction – Position: **Directeur du Laboratoire Fnac Darty**

**Place, Date / Lieu :**  
Ivry-sur-Seine, avril 8, 2022

DocuSigned by:  
*Predrag Petricevic*  
EA30F3FB8F314D0...

**CE**

**QUALITY ASSURANCE SERVICE**  
FNAC DARTY



**PROLINE**

Etablissements Darty & fils ©,  
9 Rue des Bateaux-Lavois, 94200 Ivry-sur-Seine, France

