

nutribullet
JUICER™



User guide

Contents

- 03 Important safeguards
- 06 What's included
- 07 Assembly guide
- 08 Assembly & use
 - 10 Usage instructions
 - 13 Control dial
 - 14 Juicing tips
- 18 Disassembly
- 20 Care instructions
 - 21 How to store
 - 22 Replacement Parts

Thank you for purchasing the nutribullet Juicer™.

Important safeguards

Warning! To avoid the risk of serious injury, carefully read all instructions before operating your nutribullet Juicer™. When using any electrical appliance, basic safety precautions should always be observed, including the following important information.

PERSONAL SAFETY

WARNING!

This juicer system has sharp blades and moving parts, and is **NOT** intended for use by children who lack experience and knowledge of its safe operation. They require close supervision and thorough instruction on its proper use and safe operation.

Keep the appliance and its cord out of reach of children. Children shall not play with the appliance. To eliminate a choking hazard for young children, remove and safely discard the protective cover fitted to the power plug of this juicer.

AVOID CONTACT WITH MOVING PARTS.

Keep hands, fingers, hair, clothing as well as spatulas and other utensils away from the appliance during operation.

This appliance is not intended

for use by persons (including children) with reduced physical, sensory or mental capabilities, or lack of experience and knowledge, unless they have been given supervision or instruction concerning use of the appliance by a person responsible for their safety.

SIEVE AND BLADES ARE SHARP! HANDLE WITH EXTREME CARE!

Do not touch the small cutting blades/teeth on the bottom/base of the sieve. Keep fingers away from the sharp blade in the feed chute.

Do not leave the appliance unattended when in use.

Hard fruits and vegetables will put excess strain onto the motor if a low speed is selected.

If there is a spill under, around or onto the juicer itself, disconnect the unit from the power source. Clean with a cloth and allow unit to dry completely before operating.

Do not push food into the feed chute with your fingers or utensils. Only use the food pusher provided. Do not place your hand or fingers into the feed chute when it is attached to the juicer. If food becomes lodged in the feed chute, use the food pusher provided or another piece of fruit or vegetable to push it down. Turn the motor off and ensure that all moving parts have stopped before disassembling the juicer to remove the remaining pulp.

Do not operate this or any appliance with a damaged cord or plug or after the appliance malfunctions, or is dropped or damaged in any manner. If the supply cord is damaged, it must be replaced by the manufacturer, its service agent or similarly qualified persons in order to avoid a hazard.

CAUTION: In order to avoid a hazard due to inadvertent resetting of the thermal cut-out, this appliance must not be supplied through an external switching device, such as a timer, or connected to a circuit that is regularly switched on and off by the utility.

Do not use the appliance if the rotating sieve or the protecting cover is damaged or has visible cracks.

Always ensure the juicer is turned OFF after each use. Before disassembling, make sure

the sieve has stopped rotating and the motor has completely stopped.

PRODUCT SAFETY

This juicer is only designed to juice fruits and vegetables. Please refer to the juicing guide to determine the correct speed for the fruits and vegetables selected for juicing. Do not use any frozen fruits or vegetables.

Do not use the juicer without the pulp basin and basin lid attached to the motor base. Please see assembly instructions for proper placement.

Remove and safely discard any packaging material or promotional labels before using the juicer for the first time.

Ensure that the surface where the appliance operates is stable, level, clean and dry.

Remove rind from all citrus fruits before juicing.

Do not juice stone fruit unless pits of the seed stone has been removed.

Always make sure the pulp basin cover is clamped securely in place (with locking handle) before the motor is turned on. Do not unfasten the clamps (locking handle) while the juicer is in operation.

When using this juicer, make sure there is adequate air space

around and under it for proper air circulation.

The use of attachments not recommended or sold by nutribullet® may cause fire, electric shock or injury. This juicer is for household use only. Do not use this juicer for anything other than its intended use. Do not use in moving vehicles or boats. Do not use outdoors. Misuse may cause injury.

If no speed is selected after 10 minutes, the unit will power off.

If the motor stops for any reason, unplug the power base and let it cool for at least 15 minutes.

Turn the juicer **OFF**, then unplug from the outlet when not in use, before assembling or disassembling parts and before cleaning. To unplug, grasp the plug and pull from the outlet. Never pull from the power cord.

Do not let the power cord hang over the edge of a table or counter-top.

Do not let the power cord touch hot surfaces, such as a stove or let it become tangled or knotted.

Regularly inspect the power cord, plug and the actual juicer for any damage.

To protect against fire, electrical shock and injury to persons, do not immerse the juicer, Motor Base, cord or plug in water or any other liquid.

Do not use the juicer if the rotating sieve is damaged.

Keep the juicer clean. Refer to care and cleaning section for further information.

WARNING!

Vibration can occur during normal operation.

If extreme vibration occurs, discontinue use and call Customer Service.

Any maintenance other than cleaning should be performed by an authorized electrician. Do not attempt to repair or service the juicer, contact Customer Service for assistance at www.nutribullet.com

! Save these instructions!

FOR HOUSEHOLD USE ONLY

What's included



800 WATT MOTOR BASE WITH LOCKING HANDLE

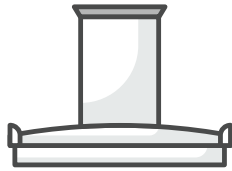

PULP BASIN COVER WITH 76 MM FEED CHUTE



FOOD PUSHER

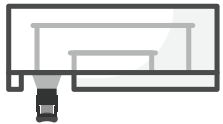

1.5L PULP BASIN WITH NO-DRIP SPOUT



STAINLESS STEEL SIEVE



800 ML JUICE PITCHER

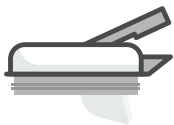

JUICE PITCHER LID WITH FROTH SEPARATOR



CLEANING BRUSH

Assembly guide

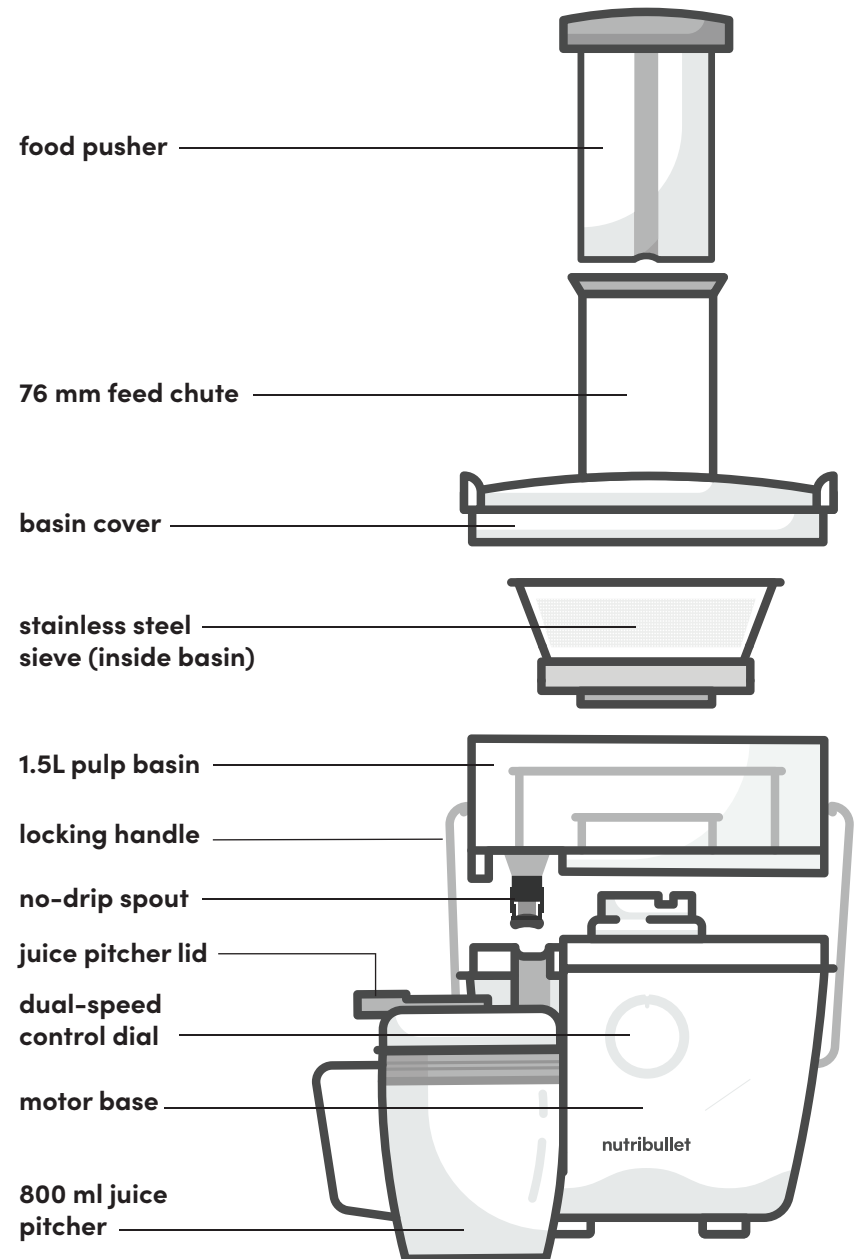

Assembly

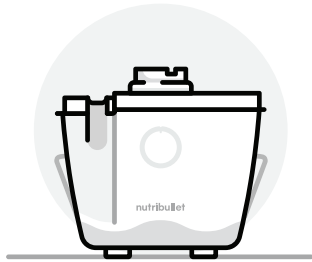

- 1 Place the **Motor Base** on a dry, level counter top. Ensure the dial is set to the "OFF" position and the unit is unplugged.

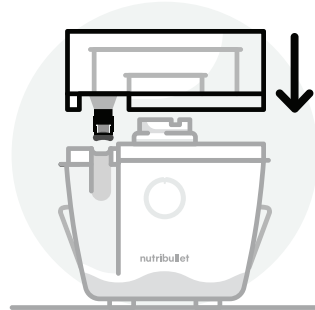

- 2 Place the **Pulp Basin** on top of the Motor Base. Align the **Pulp Basin** with the Motor Base so that the spout is aligned with the dimpled side of the Motor Base.

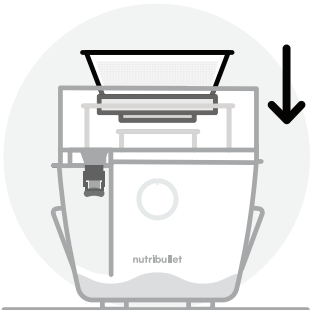

- 3 Align the **Sieve** with the motor drive coupling and push down until it clicks into place. Handle the **Sieve** by gripping the top edges being careful not to touch the sharp teeth on the base of the **Sieve**. Ensure the **Sieve** is properly seated in place and securely inside of the Pulp Basin.

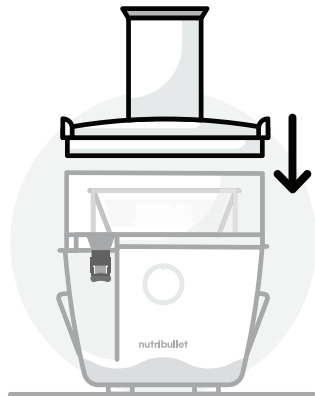

- 4 Place the **Basin Cover** over the Sieve and Pulp Basin. The side "ears" on the **Basin Cover** should align with the "ears" on the sides of the Pulp Basin.

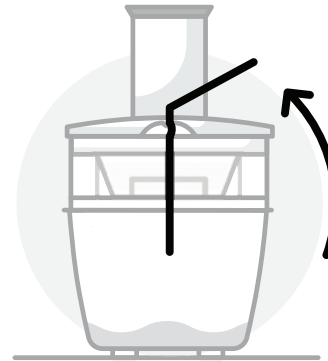

- 5 Raise the **Locking Handle** and move it into the "ears" on each side of the Basin Cover. The **Locking Handle** should be in a vertical position and locked into place.

NOTE: if the **Locking Handle** is not securely in place, the juicer will not power on.



- 6 Swing the **No-Drip Spout** cover up vertically, so that it is no longer covering the juice spout.



- 7 Place the **Juice Pitcher Lid** on top of the Juice Pitcher and open the locking lid latch.



- 8 Slightly angle the **Juice Pitcher** and place it under the juice spout. Align the spout with the hole in the **Juice Pitcher Lid** and level out the **Juice Pitcher**. It will fit snugly into the spout to hold it in place.

Usage instructions



- 1** Gather all of your desired ingredients and wash them. Prepare the ingredients to be juiced by cutting, skinning, or removing the rind, stems, or stone seeds.



- 2** After the juicer is fully assembled, plug the power cord into an outlet. Use the **Dual-Speed Control Dial** to select a speed to begin juicing. You can toggle between speeds as desired depending on the type of produce. (Refer to the chart on page 14 for recommended speeds for different types of produce).

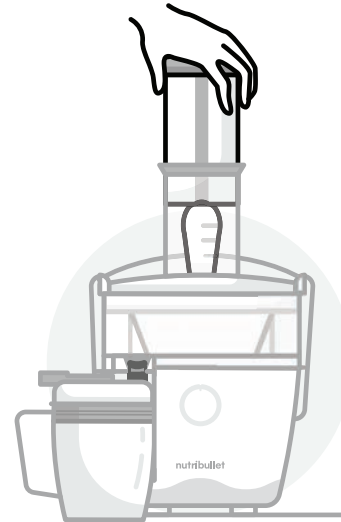

- 3** While the motor is running, begin gently guiding your ingredients into the feed chute using the **Food Pusher**.

NOTE: Do not use excess force or speed when pushing food down with the **Food Pusher**, as it will not allow for maximum juice yield.

WARNING: Never use hands/fingers or other tools to push food down the feed chute into the Sieve. Only the **Food Pusher** should be used to push down ingredients.

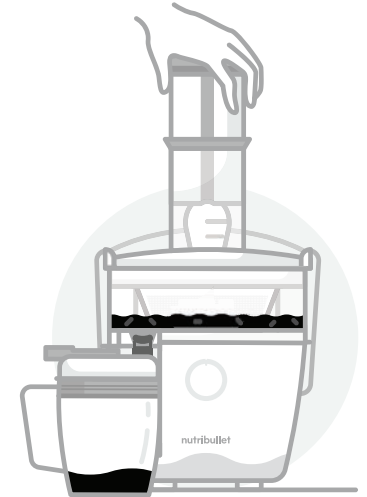

- 4** Juice will begin to flow out of the spout and into the **Juice Pitcher**, while the pulp will be separated and stored in the **Pulp Basin**.



5 When the **Pulp Basin** is completely full, it must be emptied before you continue juicing. See disassembly instructions.



6 Always be sure to turn the **Dual-Speed Control Dial** to the "**OFF**" position and wait for the **Sieve** to stop spinning before removing the **Juice Pitcher** from under the spout. Unplug the unit after each use.



7 Remove the **Juice Pitcher** from under the spout. You may close the **Juice Pitcher Lid** and store juice in the **Juice Pitcher** if desired.

NOTE: To do this, you'll first need to tip the **Juice Pitcher** forward at a slight angle, so that the lid's large hole has some separation from the spout, then you can slide out the pitcher. This is the reverse of what you did during assembly.

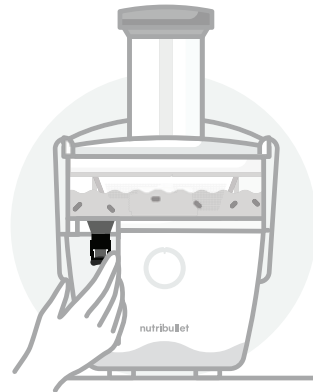

8 Immediately move the **No-Drip Spout** cover downward over the spout to avoid any residual drips onto the unit or onto the surface below the juicer.

TIP: We recommend using your left hand to pull the **Juice Pitcher** away, while using your right hand to swing the **No-Drip Spout** cover down and over the spout opening.

Control dial

DUAL-SPEED CONTROL DIAL & JUICING SETTINGS

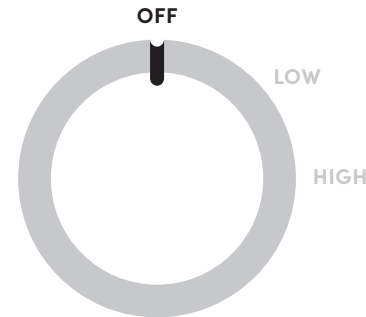

OFF:
Power is **OFF**, the juicer is not running.

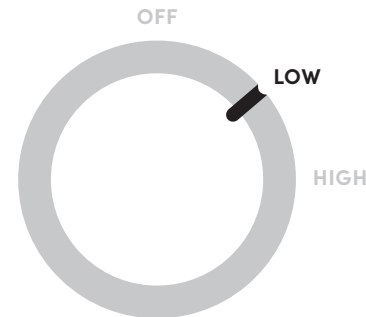

LOW:
Best for juicing softer fruits and vegetables.

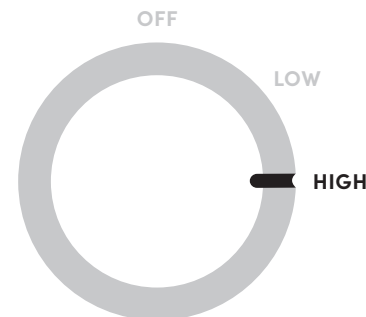

HIGH:
Best for harder produce like carrots and beets.

Juicing tips

JUICING SPEED SELECTION GUIDE

INGREDIENTS	SPEEDS	SEASONS
Apple	High	All Year
Beets	High	Summer / Fall / Winter
Blueberry	High	Summer
Broccoli	High	Fall / Spring
Brussels Sprouts	High	Fall / Winter
Cabbage	Low	Fall / Winter / Spring
Carrots	High	All Year
Cauliflower	High	Fall
Celery	High	All Year
Cucumber	Low	Summer
Fennel	High	All Year
Ginger	High	Fall
Grapes	Low	Fall
Grapefruit	Low	Winter
Kale	High	Fall / Winter / Spring
Kiwi	Low	Fall / Winter / Spring
Lemon	Low	All Year
Lime	Low	All Year
Melons (all)	Low	Summer
Orange	High	Winter
Peaches	Low	Summer
Pears	High	Fall / Winter
Pineapple	High	Fall / Winter / Spring
Plums	High	Summer
Raspberries	Low	Summer / Fall
Spinach	Low	Fall / Spring
Sweet Potato (raw)	High	Fall / Winter
Tomatoes	Low	Summer

VITAMINS / NUTRIENTS

source of quercetin
excellent source of folate
good source of vitamin C
high in vitamin C, high in folate, good source of potassium
high in vitamin C, good source of folate
high in vitamin C
excellent source of vitamin A, good source of vitamin C
high in vitamin C, good source of folate
good source of vitamin C, good source of vitamin A
good source of vitamin C
good source of vitamin C and potassium
contains vitamin C, magnesium, and potassium
good source of vitamin K
high in vitamin A, high in vitamin C
excellent source of vitamin A and vitamin C, good source of calcium and potassium
high in vitamin C, good source of potassium and vitamin E
high in vitamin C
high in vitamin C
high in vitamin A, high in vitamin C
high in vitamin C
good source of vitamin C
good source of vitamin C
high in vitamin C
high in vitamin A, vitamin C, iron, and folate, good source of magnesium
good source of potassium, high in vitamin A and vitamin C
high in vitamin A, high in vitamin C, good source of potassium

PROPER PRODUCE PREP

Prepare fruit and veggies before inserting them into the juicer:

- Properly clean produce (rinse with lukewarm water, produce wash, or water and apple cider vinegar).
- Peel or remove skin as needed, and chop food items down to the right size – just small enough to fit easily into the feed chute, without having to force the pieces down with the **Food Pusher**.
- Remove rind from all citrus fruits before juicing.
- Remove large pits and seeds from stone fruits before juicing.

FEED CHUTE

- Never place your hand or fingers into the feed chute when it is attached to the appliance.
- Always start the juicer before adding food to the feed chute. The juicer must be running when items enter it.
- Do not overload the feed chute. Items must be added gradually, at a pace the juicer can keep up with.
- Use only the provided **Food Pusher** to push food into the feed chute. Never use fingers, utensils, or any other apparatus.
- Never use excessive force to push items into the feed chute.
- When juicing, ensure all produce has moved through the feed chute and into the **Sieve** before adding more.
- If any food gets stuck in the feed chute, use the **Food Pusher** to move it down the chute and into the **Sieve**.

CONSUMING JUICE & PULP

Instead of composting or throwing away the pulp left over after juicing, you can choose to consume it. See our **Recipe Guide** for some fun tips on what to do with the pulp. By using these creative ideas, you can enjoy pulp in a variety of delicious (and healthy) ways.

- Whether you prefer sweet or savory, you can use pulp to create some tasty treats!
- For best taste, consume fresh juice and pulp within 48 hours of juicing.

NO-GO FOODS

Foods that should NEVER be used in this juicer:

- Foods that do not contain juice to extract (for example, bananas or avocados).
- Frozen fruits or vegetables.
- Stone fruits that have large pips or seeds that have not been removed. Stone fruits may be used only if the seed or pip has been removed.

OVERHEATING

- If the motor overheats, the juicer will turn off.
- If the juicer stops working, unplug it and allow it to cool down for at least fifteen minutes before attempting to use again.

Disassembly



- 1** Ensure the unit is powered down, turned “OFF”, and unplugged.

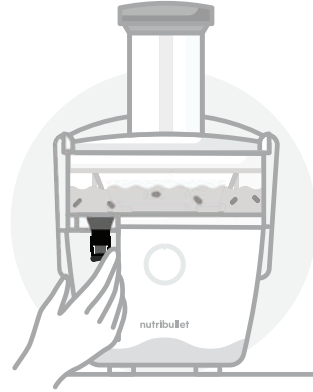

- 2** Remove the pitcher from under the spout. To prevent drips use the **No-Drip Spout** cover to close the juice spout.

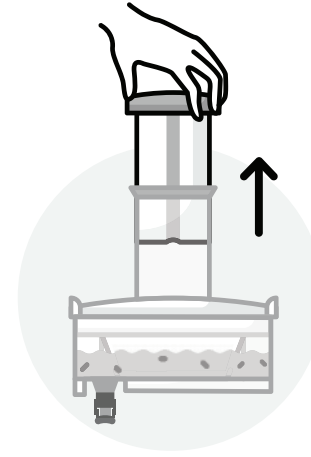

- 5** Remove the **Food Pusher** by lifting it out of the feed chute.

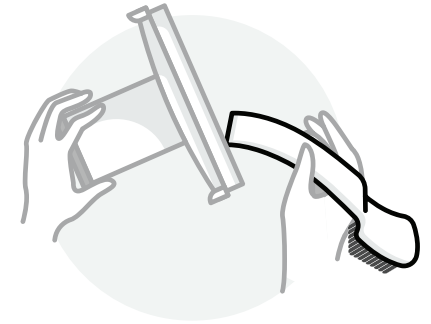

- 6** Lift the Basin Cover vertically off of the Pulp Basin and remove any pulp from the inside of the cover. You may use the flat end of the **Cleaning Brush** to scrape pulp off of the cover.

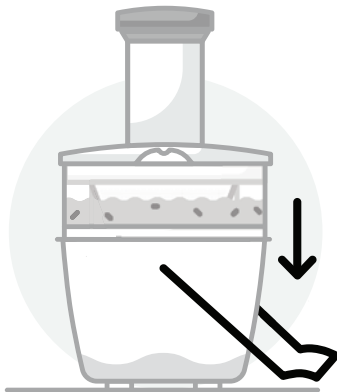

- 3** Unlock the **Locking Handle** from the **Basin Cover** by pulling the handle backward out of the “ears” on either side of the **Basin Cover**. Move the handle down.

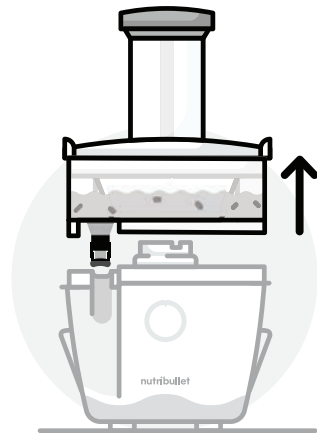

- 4** Remove the **Pulp Basin** from the Motor Base by pulling upwards with the **Basin Cover** and **Sieve** still in place, and take it directly to your sink.

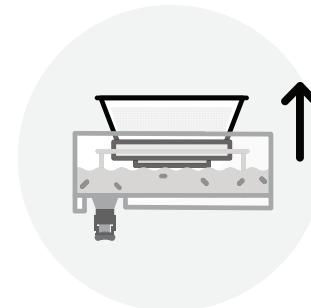

- 7** Gently lift the **Sieve** vertically out of the center of the Pulp Basin. Clean the **Sieve** right away (see care instructions).

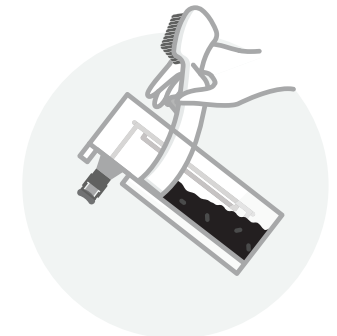

- 8** Empty the **Pulp Basin**. Use the flat end of the **Cleaning Brush** to easily scrape out the pulp and set it aside for use in other recipes or composting. You can also empty the pulp into your waste bin or compost.

Care & maintenance

Please follow the below cleaning instructions before the first use, and after each use.

Cleaning the nutribullet Juicer Pro™ is quick and easy. All components except for the Food Pusher and Motor Base are dishwasher safe. Read on for some cleaning tips and best practices.

- 1 Always ensure the **Motor Base** is unplugged before you begin assembly, disassembly, cleaning or storage of the unit.
- 2 Once the **Pulp Basin** is emptied, rinse all parts under running water.
- 3 Use the **Cleaning Brush** to scrub the **Sieve** under running water. Be sure to properly clean the **Sieve** every time you juice, as minerals from fruits and vegetables can cause build-up in the **Sieve** which may prohibit maximum juice extraction.

 **WARNING:** Always use precaution when cleaning the **Sieve**, as it contains sharp blade teeth on the flat disc part.

TIP: Always clean the **Sieve** as soon as possible after juicing using the **Cleaning Brush**. If allowed to sit, pulp will dry on the **Sieve** and it will become more difficult to scrub blocked holes. If this happens, be sure to allow the **Sieve** to soak in hot water for 30 minutes.

- 4 All Juicer Pro components except the **Motor Base** are dishwasher safe. You may also hand wash with warm soapy water.

TIP: Do not use the Sterilize cycle on your dishwasher to clean your juicer as it may cause parts to deform.

- 5 Wipe down **Motor Base** with a clean, damp cloth.

 **WARNING:** Never submerge **Motor Base** into water or other liquid.

Cleaning instructions for your nutribullet Juicer Pro™ storage accessories:

- **Glass Storage Bottles** and lids are dishwasher safe.
- **Freezer Trays** and lids are dishwasher safe.

Juice & unit storage

Included with your Juicer Pro are some great storage accessories: a Juice Pitcher, two Juice Storage Bottles, and two Freezer Trays.

The storage accessories give you three options for storing juice:

- 1 **IN THE PITCHER:**
The **Juice Pitcher** stores up to 800 ml. Make sure to store the pitcher upright in your refrigerator, with lid tightly sealed, latch closed, and nothing atop the lid.
- 2 **IN THE BOTTLES:**
Use each **Storage Bottle** to save up to 350 ml of juice, so you can enjoy it later — either at home or on the go. Fill up the bottles leaving about .6 cm of room at the top, leaving just enough air in the bottle.
- 3 **IN THE TRAYS:**
Each **Freezer Tray** holds a total of 470 ml: one tray has eight 60 ml wells, and the other tray has four 120 ml wells. These are a great way to preserve juice longer-term, then defrost it anytime for a full drinkable portion. Or, use the trays to make frozen juice shots. (See our **Recipe Guide** for some inspiring recipes for frozen juice shots to add to

your favorite beverages, or to drink on their own.)

For best taste, consume fresh juice and pulp within 48 hours of juicing.

Do not place anything on top of the Pitcher Lid when storing in the refrigerator.

Store remaining pieces of the unit in a safe place where they will not be damaged and won't cause harm as some pieces are sharp!

Troubleshooting guide

1 PROBLEM: The power button flashes three times and then remains illuminated when I select a speed.

SOLUTION: This means that the unit is not properly assembled. Ensure the **Pulp Basin** is properly seated on top of the **Motor Base**, and the **Locking Handle** is locked into place.

2 PROBLEM: The juicer stopped in the middle of juicing, and the power button flashed.

SOLUTION: Ensure the **Locking Handle** is securely locked into place.

3 PROBLEM: The juicer stopped in the middle of juicing, and the power button remains illuminated.

SOLUTION: You have exceeded 10 minutes of continuous running time. Unplug the juicer and keep the unit off for 15 minutes before continuing use.

4 PROBLEM: The juicer has stopped running, and all lights flashed three times.

SOLUTION: The juicer has overheated. Unplug the unit and allow it to cool down for 15 minutes before continuing use.

EN/ Explanation of the markings



EN/ This marking indicates that this product should not be disposed with other household wastes throughout the EU. To prevent possible harm to the environment or human health from uncontrolled waste disposal; recycle it responsibly to promote the sustainable reuse of material resources. To return your used device, please use the return and collection systems or contact the retailer where the product was purchased. They can take this product for environmental safe recycling.



EN/ This product complies with the European regulation no. 1935/2004 on materials and articles intended to come into contact with food.

Replacement parts

To order additional parts and accessories, please visit our website at nutribullet.com

1 (800) 523-5993 | nutribullet.com

nutribullet® is the registered trademark of CAPBRAN HOLDINGS, LLC
Copyright © 2020 CAPBRAN HOLDINGS, LLC. Distributed by CAPITAL BRANDS
DISTRIBUTION, LLC. LOS ANGELES, CA 90025 USA
All Rights Reserved. MADE IN CHINA

Illustrations may differ from the actual product. We are constantly striving to improve our products, therefore the specifications contained herein are subject to change without notice.

210927_NBJ93100