

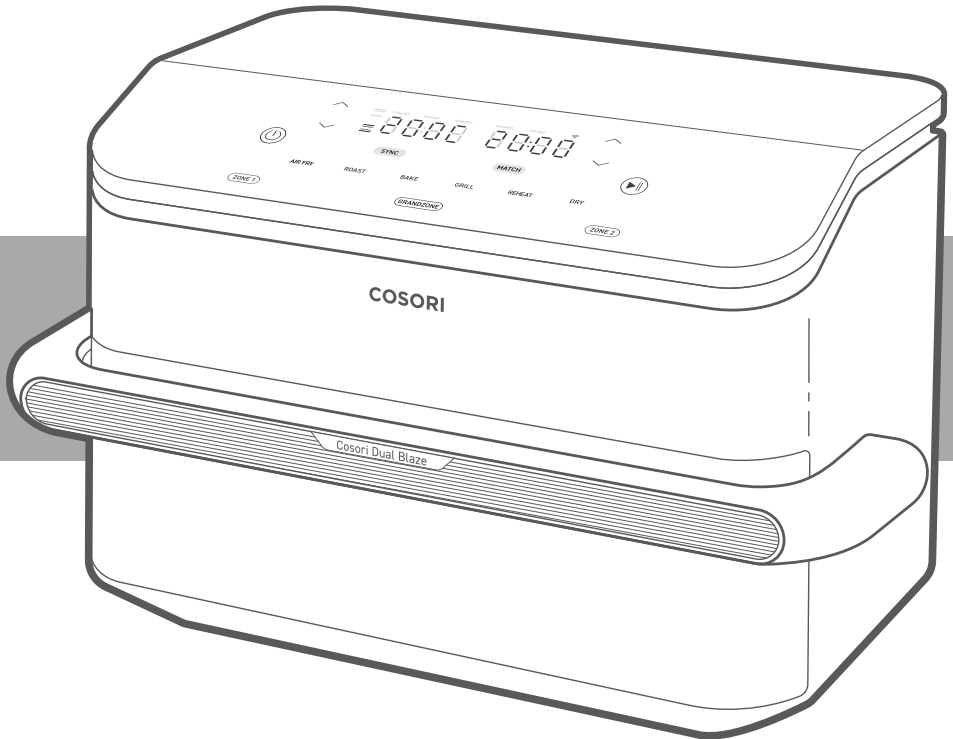

COSORI

User Manual

Dual Blaze TwinFry™ 10-Litre Air Fryer



Questions or Concerns?
support.uk@cosori.com

 Thank you for
your purchase! 

(We hope you love your new smart air fryer as much as we do)



Get Creative With COSORI

Download the free VeSync app to access original recipes and video tutorials from the COSORI chefs, interact with our online community, and more!



explore

our digital recipe gallery
cosori.com



enjoy

weekly, featured recipes
made exclusively by our in-house chefs



CONTACT OUR CHEFS

Our helpful, in-house chefs are ready to assist you with any questions you might have!

Email: recipes@cosori.com

On behalf of all of us at COSORI,

Happy cooking!

Table of Contents

Package Contents	3
Specifications	3
Important Safeguards & Warnings	4
Getting To Know Your Smart Air Fryer	8
Before First Use	11
Using Your Smart Air Fryer	13
Care & Maintenance	21
Accessories	21
Troubleshooting	22
Limited Warranty Information	25
Customer Support	27

Package Contents

1 x Dual Blaze TwinFry™ 10-Litre Air Fryer
2 x Crisper Plate
1 x Basket Divider
1 x Silicone Tongs
1 x User Manual
1 x Quick Start Guide

Specifications

Model	CAF-TF101S-AUK
Power Supply	AC 220–240V, 50Hz
Rated Power	2,700W
Capacity	10 L
Temperature Range	35°–240°C / 95°–465°F
Time Range	1 min–48 hr
Dimensions (including handle)	33.8D x 51.8W x 31.3H cm / 13.3D x 20.4W x 12.3H in
Weight	9.2 kg / 20 lb
Networked Standby Mode Power Consumption	<2.0W
Standby/Off Mode Power Consumption	<1.0W

READ AND SAVE THESE INSTRUCTIONS IMPORTANT SAFEGUARDS & WARNINGS

Follow basic safety precautions when using your air fryer. Read all instructions.

Key Safety Points

- **Do not** touch hot surfaces. Use handles.
- **Do not** block any ventilation openings. Hot steam is released through openings. Keep your hands and face clear of openings.
- **CAUTION:** The hot crisper plates may fall out when turning the basket over.

Note:

- *Firmly insert the crisper plates into the basket to reduce the chance of them falling out.*
- **Always** use tongs to carefully remove hot food.

General Safety

- To protect against electric shock, **do not immerse the air fryer** housing, cord, or plug in water or other liquids.
- Close supervision is necessary when the air fryer is used by or near children.
- Unplug when not in use, and before cleaning. Allow to cool before putting on or taking off parts.
- **Do not** use your air fryer if it is damaged, not working, or if the cord or plug is damaged. Contact **Customer Support** (see page 27).
- **Do not** use third-party replacement parts or accessories, as this may cause injuries.
- **Do not** use outdoors.
- **Do not** place the air fryer or any of its parts on a stove, near gas or electric burners, or in a heated oven.
- Be extremely cautious when moving your air fryer (or removing the basket) if it contains hot oil or other hot liquids.
- **Always** place the crisper plates on a heat-resistant surface after removing them from the basket.
- **Do not** clean with metal scouring pads. Metal fragments can break off the scouring pad and touch electrical parts, creating a risk of electric shock.
- **Do not** place anything on top of your air fryer. **Do not** store anything inside your air fryer.
- This air fryer can be used by children 8 years and older as well as persons with reduced physical, sensory, or mental capabilities or lack of experience and knowledge if they have been given supervision or instruction concerning use of the air fryer in a safe way and understand the hazards involved.
- Cleaning and user maintenance shall not be made by children unless they are older than 8 and supervised.
- Children should be supervised to ensure that they **do not** play with the air fryer.
- This air fryer is not intended to be operated by means of an external timer or separate remote-control system.
- For instructions on cleaning the accessories, see **Care & Maintenance** (page 21).
- **Only** use your air fryer as directed in this manual.
- Not for commercial use. Household use **only**.

While Air Frying

- An air fryer works with hot air **only**. **Never** fill the basket with oil or fat.
- **Never** use your air fryer without the basket in place.
- **Do not** place oversized foods or metal utensils into your air fryer.
- **Do not** use cooking sprays with propellants. Propellants may damage the air fryer basket's coating.
- **Do not** overfill the air fryer basket. Heaping amounts of food may touch the heating coils and cause a fire hazard.
- **Do not** touch the basket or crisper plates during or immediately after air frying.
- **Do not** place paper, cardboard, non-heat-resistant plastic, or similar materials into your air fryer. You may use parchment paper or foil.
- **Never** put baking paper, parchment paper, or foil into the air fryer without food on top. Air circulation can cause paper to lift and touch heating coils.
- **Never** put thin or lightweight food like cornflakes into the air fryer. Pay attention to small pieces of food. Air circulation can cause thin, lightweight, or small pieces of food to lift and touch heating coils.
- **Always** use heat-safe containers. Be extremely cautious if using containers that aren't metal or glass.
- Keep your air fryer away from flammable materials (curtains, tablecloths, etc.). Use on a flat, stable, heat-resistant surface away from heat sources or liquids.
- Immediately turn off and unplug your air fryer if you see dark smoke coming out. White smoke is normal, caused by heating fat or food splashing, but dark smoke means that food is burning or there is a circuit problem. Wait for smoke to

clear before pulling the basket out. If the cause was not burnt food, contact

Customer Support (page 27).

- **Do not** leave your air fryer unattended while in use.
- To turn the air fryer off, press \odot once. \odot will remain orange and all other buttons will turn off.
- To unplug, grab the plug and pull from the outlet. **Never** pull from the power cord.

Power & Cord

- Turn off the air fryer before removing the plug from the outlet.
- **Do not** let the power cord (or any extension cord) hang over the edge of a table or counter, or touch hot surfaces.
- If the power-supply cord is damaged, it must be replaced by VESYNC (SINGAPORE) PTE. LTD. or similarly qualified persons in order to avoid an electric or fire hazard. Please contact **Customer Support** (page 27).
- Remove and discard the plug's protective cover to prevent a choking hazard.
- **Never** use an outlet below the counter when plugging in your air fryer.
- Your air fryer should **only** be used with **220–240V, 50Hz** electrical systems. **Do not** plug into another type of outlet.
- Keep the air fryer and its cord out of reach of children less than 8 years old.

Note: This air fryer uses a short power-supply cord to reduce the risk of entangling or tripping. Use extension cords with care. The marked electrical rating of the extension cord must be as great as the rating of the air fryer (see **Specifications**, page 3).

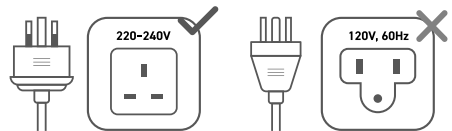

Extension Cords

- Longer extension cords are available and may be used if care is exercised in their use. If a longer extension cord is used:
 - The marked electrical rating of the extension cord should be at least as great as the electrical rating of the air fryer.
 - The cord should be arranged so that it will not drape over the countertop or tabletop where it can be pulled on by children or tripped over unintentionally.
- If the power-supply cord is damaged, it must be replaced by VESYNC (SINGAPORE) PTE. LTD. or similarly qualified persons in order to avoid an electric or fire hazard. Please contact **Customer Support** (page 27).

Electromagnetic Fields (EMF)

The COSORI Smart Air Fryer complies with all standards regarding electromagnetic fields (EMF). If handled properly and according to the instructions in this user manual, the appliance is safe to use based on scientific evidence available today.

Note: Items marked with the following symbol may reach high temperatures and should be handled carefully.



CAUTION: Hot surface.

SAVE THESE INSTRUCTIONS



This symbol means the product must not be discarded as household waste, and should be delivered to an appropriate collection facility for recycling. Proper disposal and recycling helps protect natural resources, human health and the environment.

For more information on disposal and recycling of this product, contact your local municipality, disposal service, or the shop where you bought this product.

This product is RoHS compliant.

This product is in compliance with Directive 2011/65/EU, and its amendments, on the restriction of the use of certain hazardous substances in electrical and electronic equipment.

VeSync App Setup

Note:

- The VeSync app is continually being improved and may change over time. If there are any differences, follow the in-app instructions.
- Requires device to run app, Wi-Fi or mobile data, and iOS version 12 or Android version 7 (or above). Standard data and messaging rates may apply. Registration is required.

1. To download the VeSync app, scan the QR code or search “VeSync” in the Apple App Store® or Google Play Store.

Note: For Android™ users, choose “Allow” to use VeSync.



2. Open the VeSync app. If you already have an account, tap **Log In**. To create a new account, tap **Sign Up**.

Note: You must create your own VeSync account to use third-party services and products. These will not work with a guest account. With a VeSync account, you can also allow your family and friends to control your smart air fryer.

3. Plug in your smart air fryer to enter pairing mode.
4. Tap + and select your smart air fryer.
5. Follow the in-app instructions to set up your smart air fryer.

Note:

- You can change the name and icon at any time by going to the smart air fryer screen and tapping .

Disconnecting From Wi-Fi®

- To disconnect Wi-Fi®, press and hold the  for 15 seconds until the Wi-Fi indicator turns off. This will restore the smart air fryer’s default settings and disconnect it from the VeSync app.
- To reconnect, please follow the instructions in the VeSync app for adding a device.

VeSync App Features

The VeSync app allows you to access additional smart air fryer functions, including those listed below.

Remote Control

- All smart air fryer functions can be controlled remotely, except for starting cooking (to comply with UL safety regulations).
- Cooking progress can be monitored from a distance.

In-App Recipes

- Pre-programmed recipes made by COSORI’s in-house chefs are available on the app. These recipes automatically set the recommended time and temperature.
- Create and save custom recipes.

Note: The VeSync app is continually updated and app features will expand.

GETTING TO KNOW YOUR SMART AIR FRYER

Note:

- **Do not** try to open the top of the air fryer. This is not a lid.
- The basket and crisper plates are made of aluminium metal with nonstick coating.

Air Fryer Diagram

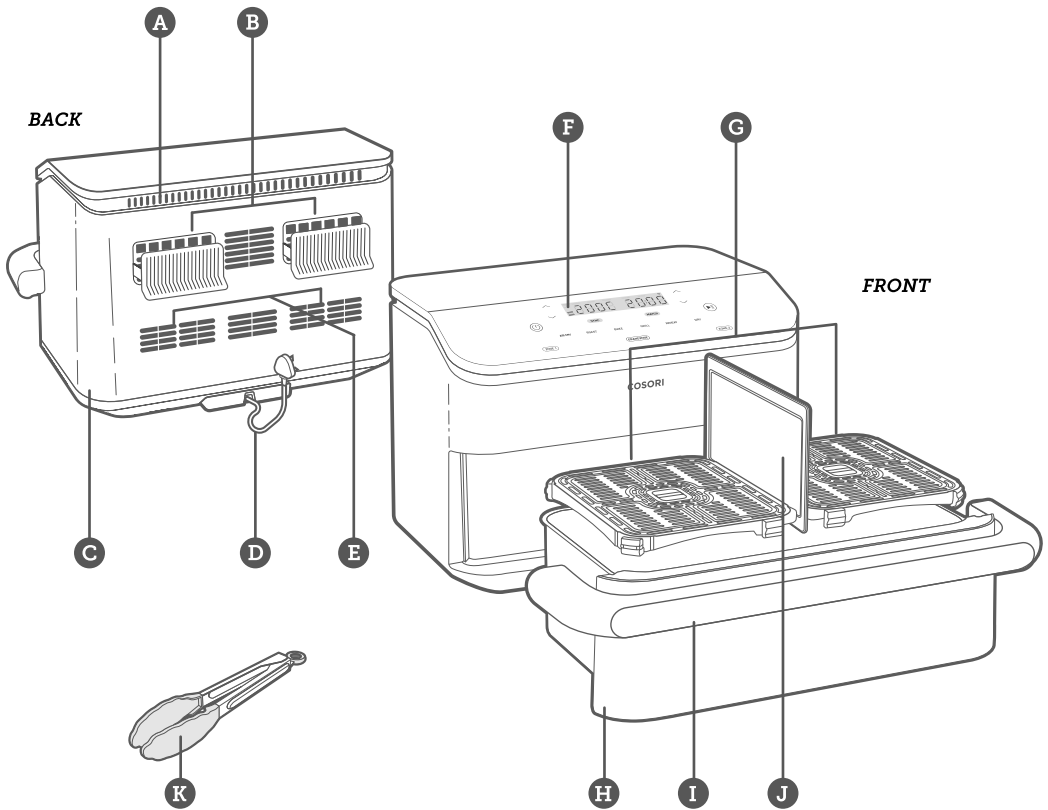

- A. Air Inlet
- B. Air Outlet
- C. Housing Handles
- D. Power Cord

- E. Vents
- F. Control Panel
- G. Crisper Plates
- H. Basket

- I. Basket Handle
- J. Basket Divider
- K. Silicone Tongs

Display Diagram

Note: When you tap a cooking function button, it will turn orange to show that it's selected.

Control Panel

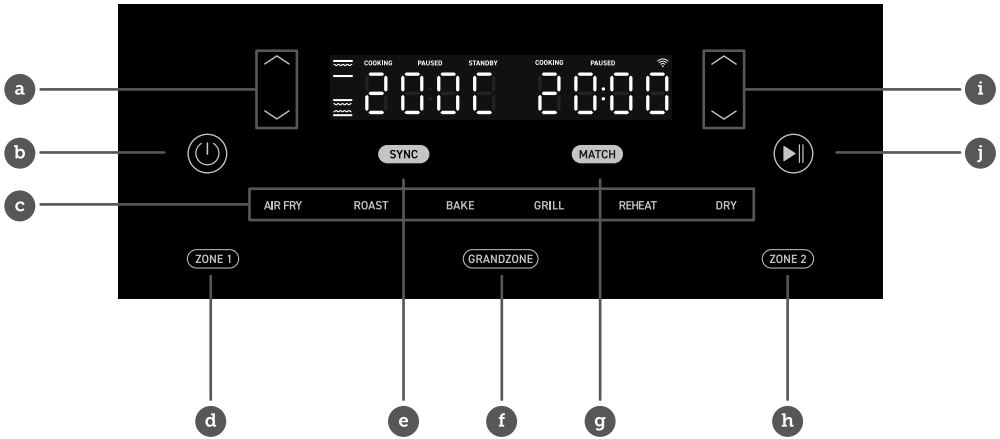

- a. Increase/Decrease Temperature
- b. On/Off
- c. Cooking Functions
- d. ZONE 1
- e. SYNC
- f. GRANDZONE
- g. MATCH
- h. ZONE 2
- i. Increase/Decrease Time
- j. Start/Pause

Display

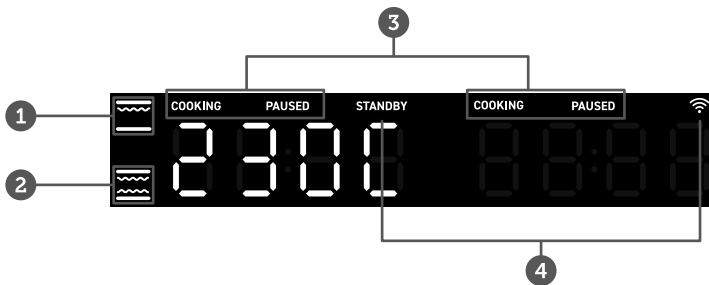

1. Top heating elements on
2. Top and bottom heating elements on
3. Cooking Status
4. Wi-Fi Indicator

Note: The Wi-Fi indicator tells you your VeSync configuration status. See the VeSync in-app instructions for more information.

Display (cont.)



Temperature Display



Time Display

Display Messages

Cooking

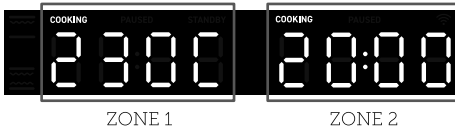

Paused

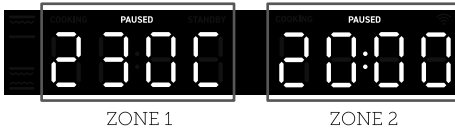

Basket is Removed/Cooking Paused



Cooking Finished



Cooling



BEFORE FIRST USE

Setting Up

1. Remove all packaging from inside and outside the air fryer, including any temporary stickers and plastic wrap.
2. Place the air fryer on a stable, level, heat-resistant surface. Keep away from areas that can be damaged by hot air or steam (such as walls or cupboards).

Note: Leave 13 cm / 5 inches of space behind and above the air fryer. [Figure 1.1] Leave enough room in front of the air fryer to remove the basket.

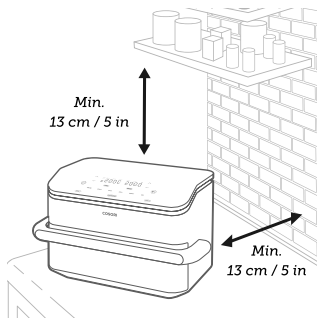

Figure 1.1

3. Wash the basket, basket divider, and crisper plates thoroughly, using either a dishwasher or a non-abrasive sponge.
4. Wipe the inside and outside of the air fryer with a slightly moist cloth. Dry with a towel.
5. Firmly insert the crisper plates and divider into the basket, then place the basket inside the air fryer. [Figure 1.2]

Note: When inserting the crisper plates, tilt the crisper plate to one side first, then press down on the other side. The crisper plates can only fit one way in the basket. [Figure 1.3]

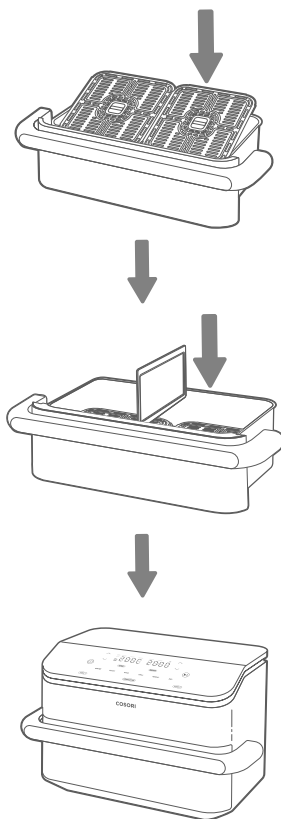

Figure 1.2

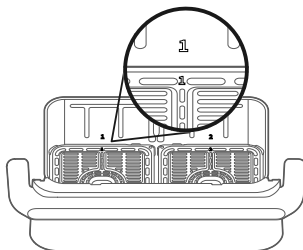





Figure 1.3

Test Run

A test run will help you become familiar with your air fryer, make sure it's working correctly, and clean it of possible residues in the process.

1. Make sure the air fryer baskets are empty and plug in the air fryer.
2. Tap .
3. Tap **GRANDZONE**. The display will show "200°C" and "20 MIN".
4. Tap  to change the time to 10 minutes.
5. Tap  to begin heating. When the test run is done, the air fryer will beep.
6. Remove the basket. Let the basket cool completely for 10–30 minutes.

Note:

- Any air fryer may have a plastic smell from the manufacturing process. This is normal. If the plastic smell does not decrease after a test run, contact **Customer Support** (see page 27).
- Use caution when turning the basket over after cooking, as the hot crisper plates may fall out and create a safety hazard.

Silicone Stoppers

- The crisper plate contain 4 silicone stoppers made of food-safe material. These stoppers keep the plate fitted to the bottom of the basket.
- When placing the crisper plates into the basket, tilt the crisper plate to insert one side first, then press down on the other side. The crisper plates can only fit one way in the basket. **[Figure 1.4]**

Note: Forcing the crisper plate into the basket incorrectly may cause damage.

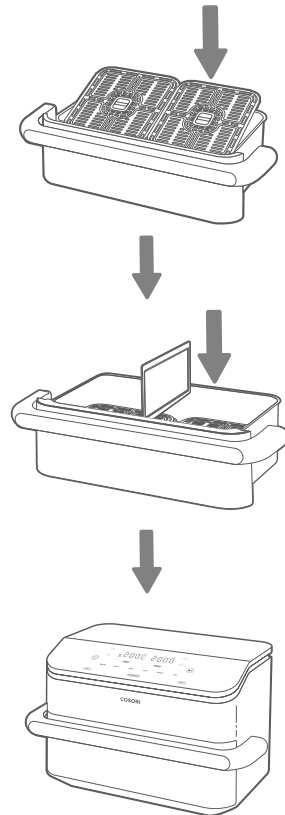

Figure 1.4

- Make sure children **do not** play with the silicone stoppers or swallow them.

USING YOUR SMART AIR FRYER

You can use the VeSync app to monitor cooking, follow in-app recipes, and access additional features. For a list of smart features, see **VeSync App Features** (Page 7).

Air Frying

Note:

- **Do not** place anything on top of your air fryer. This will disrupt airflow and cause poor air frying results. [Figure 2.1]
- An air fryer is not a deep fryer. **Do not** fill the basket with oil, frying fat, or any liquid.
- Be careful of hot steam when taking the basket out of the air fryer.

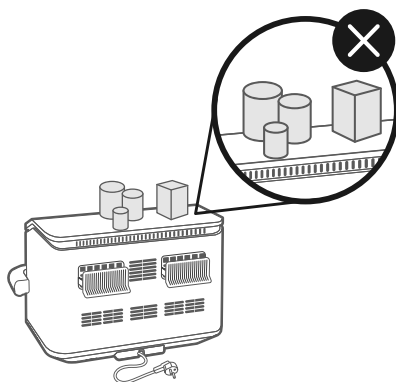

Figure 2.1

Cooking Chart

Results may vary. For recipes and cooking inspiration, check out the VeSync app.

Function	Temp	Time	Temp Range	Time Range	Upper Power	Lower Power
AIR FRY	200°C	20 min	120°–205°C	1-60 min	🔥🔥🔥	🔥🔥🔥
ROAST	190°C	30 min	120°–205°C	1-240 min	🔥🔥🔥	🔥🔥🔥
BAKE	160°C	25 min	80°–205°C	1-240 min	🔥🔥🔥	🔥🔥🔥
GRILL	240°C	10 min	205°–240°C	1-30 min	🔥🔥🔥	N/A
REHEAT	165°C	15 min	40°–205°C	1-60 min	🔥🔥🔥	🔥🔥🔥
Dehydrate (DRY)	55°C	6 hr	35°–95°C	30 min-48H	🔥🔥🔥	🔥🔥🔥

Note: Upper and Lower Power here are schematic, not actual firepower. The upper and lower heating elements' actual temperature may vary. The temperature range shown in the diagram only roughly shows the maximum temperature each heating element can achieve.

Cooking in the Grandzone

1. Place the crisper plates into the basket. **[Figure 3.1]**

Note:

- The crisper plates allow excess oil to drip down to the bottom of the basket.
- When placing the crisper plates into the basket, tilt the crisper plate to insert one side first, then press down on the other side.
- The crisper plates may not be needed for certain recipes, such as muffins and breads.

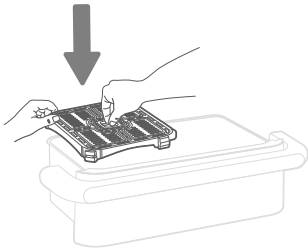

Figure 3.1

2. Tap \odot .
3. Select **GRANDZONE**.
4. Select a cooking function.

Note: Cooking functions are programmed with an ideal time and temperature for cooking certain foods. You can also customise their time and temperature.

5. To customise time and temperature tap \wedge or \vee for time and temperature. You can do this anytime during cooking. To go back to a function's default settings right after changing them, press the function's button again. **[Figure 3.2]**

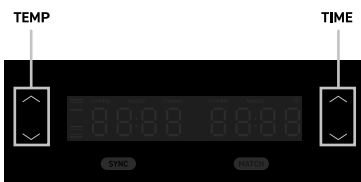

Figure 3.2

7. The air fryer will beep when finished. The display will show "End".
8. Take the basket out of the air fryer, being careful of hot steam. Use tongs or heat-safe utensils to remove the food from the basket.

CAUTION: The hot crisper plates may fall out when turning the basket over.

- a. Make sure the basket is resting on a flat surface.
- b. Watch for hot oil or fat collected in the basket. To avoid splashing, drain oil before replacing the basket. **[Figure 3.3]**

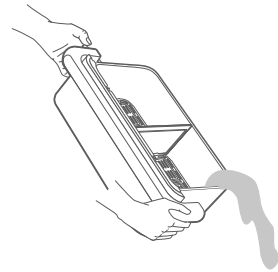

Figure 3.3

9. Allow to cool before cleaning.

6. Tap $\blacktriangleright\parallel$ to begin air frying.

Cooking in a Single Zone

1. Place the crisper plates and divider into the basket. **[Figure 4.1]**

Note:

- The crisper plates allow excess oil to drip down to the bottom of the basket.
- When placing the crisper plates into the basket, tilt the crisper plate to insert one side first, then press down on the other side.
- The crisper plates may not be needed for certain recipes, such as muffins and breads.

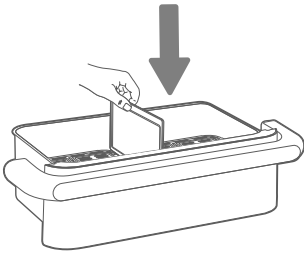

Figure 4.1

2. Tap \odot .
3. Select the zone's button you want to use.
4. Select a cooking function.

Note: Cooking functions are programmed with an ideal time and temperature for cooking certain foods. You can also customise their time and temperature.

5. Optionally, change the temperature and time by tapping \wedge or \vee . **[Figure 4.2]**
6. Tap \blacktriangleright to begin air frying.

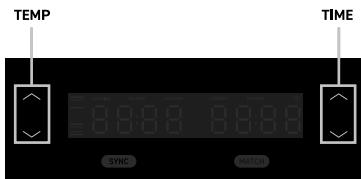

Figure 4.2

7. The air fryer will beep when finished. The display will show "End".

8. Take the basket out of the air fryer, being careful of hot steam. Use tongs or heat-safe utensils to remove the food from the basket.

CAUTION: The hot crisper plates may fall out when turning the basket over.

- a. Make sure the basket is resting on a flat surface.
- b. Watch for hot oil or fat collected in the basket. To avoid splashing, drain oil before replacing the basket. **[Figure 4.3]**

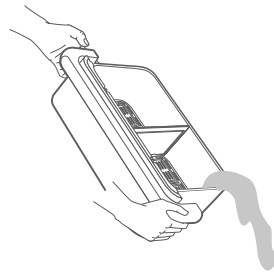

Figure 4.3

9. Allow to cool before cleaning.





Cooking in Dual Zones

Cook using two zones to prepare different foods at the same time. **ZONE 1** and **ZONE 2** can be controlled separately from one another.

1. Place the crisper plates and divider into the basket.

Note:

- The crisper plates allow excess oil to drip down to the bottom of the basket.
- When placing the crisper plates into the basket, tilt the crisper plate to insert one side first, then press down on the other side.
- The crisper plates may not be needed for certain recipes, such as muffins and breads.

2. Tap .
3. Select **ZONE 1**.
4. Select a cooking function.
5. To customise time and temperature tap  or  for time and temperature. You can do this anytime during cooking. To go back to a function's default settings right after changing them, press the function's button again.
6. Select **ZONE 2** and repeat steps 4 and 5.
7. Tap  to begin air frying.

Note: If you decide the food in one of the zones is done before the cook time is up, you can pause a zone by selecting that zone and tapping .

8. The air fryer will beep when finished. The display will show "End".
9. Take the basket out of the air fryer, being careful of hot steam. Use tongs or heat-safe utensils to remove the food from the basket.

CAUTION: The hot crisper plates may fall out when turning the basket over.

10. Make sure the basket is resting on a flat surface.
11. Watch for hot oil or fat collected in the basket. To avoid splashing, drain oil before replacing the basket. **[Figure 5.1]**

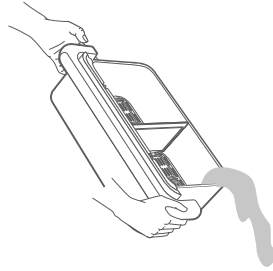



Figure 5.1



12. Allow to cool before cleaning.

Pausing Cooking

Cooking will automatically pause when the basket is removed. Reinsert the basket to resume cooking.

Optionally, tap  to pause cooking of both zones. Tap  again to resume cooking.

Pausing the cook time in one zone (while using both zones)

1. Select the zone you want to pause.
2. Tap  to pause cooking.
3. To resume the paused zone, tap  again.

Note: You can adjust the settings (cooking function, time, and temperature) during pause.

Ending the cook time in one zone (while using both zones)

If you decide the food in one of the zones is done before the cook time is up, you can **stop a zone**. Press and hold that zone's button for 3 seconds.

Sync Cooking

Program the zones to finish cooking at the same time when they use different functions, cook times, and temperatures.

1. Place the crisper plates and divider into the basket. **[Figure 6.1]**

Note:

- The crisper plates allow excess oil to drip down to the bottom of the basket.
- When placing the crisper plates into the basket, tilt the crisper plate to insert one side first, then press down on the other side.
- The crisper plates may not be needed for certain recipes, such as muffins and breads.

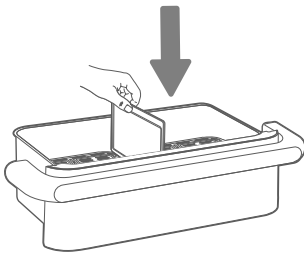

Figure 6.1

2. Tap \odot .
3. Select **ZONE 1**. Choose a cooking function then change the temperature and time by tapping \wedge or \vee .
4. Select **ZONE 2**. Choose a cooking function then change the temperature and time by tapping \wedge or \vee .
5. Tap **SYNC**.
6. Tap \blacktriangleright . The zone with the longest time will begin cooking. The other zone will display "HoLd". The unit will start the second zone when both zones have the same time remaining.

Note: If you decide the food in one of the zones is done before the cook time is up, you can **stop a zone**. Press and hold that zone's button for 3 seconds.

7. The air fryer will beep when finished. The display will show "End".

8. Take the basket out of the air fryer, being careful of hot steam. Use tongs or heat-safe utensils to remove the food from the basket.

CAUTION: The hot crisper plates may fall out when turning the basket over.

- a. Make sure the basket is resting on a flat surface.
- b. Watch for hot oil or fat collected in the basket. To avoid splashing, drain oil before replacing the basket. **[Figure 6.2]**

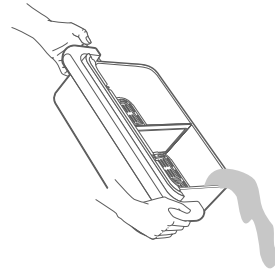

Figure 6.2

9. Allow to cool before cleaning.

Match Cooking

Mirror settings across ZONE 1 and ZONE 2 to cook with the same function, temperature, and time. This allows you to cook large quantities at the same time or different foods using the same settings.

1. Place the crisper plates and divider into the basket. **[Figure 7.1]**

Note:

- The crisper plates allow excess oil to drip down to the bottom of the basket.
- When placing the crisper plates into the basket, tilt the crisper plate to insert one side first, then press down on the other side.
- The crisper plates may not be needed for certain recipes, such as muffins and breads.

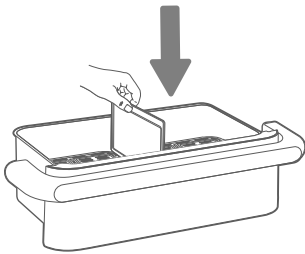

Figure 7.1

2. Tap \odot .
3. Select **ZONE 1**. Choose a cooking function then change the temperature and time by tapping \wedge or \vee .
4. Tap **MATCH** to copy **ZONE 1** settings to **ZONE 2**.
5. Tap $\blacktriangleright\parallel$ to begin cooking in both zones.
6. The air fryer will beep when finished. The display will show "End".
7. Take the basket out of the air fryer, being careful of hot steam. Use tongs or heat-safe utensils to remove the food from the basket.

CAUTION: The hot crisper plates may fall out when turning the basket over.

- a. Make sure the basket is resting on a flat surface.
- b. Watch for hot oil or fat collected in the basket. To avoid splashing, drain oil before replacing the basket. **[Figure 7.2]**

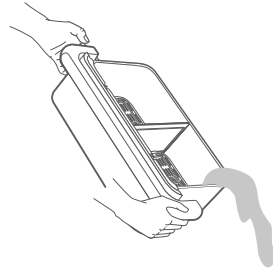

Figure 7.2

8. Allow to cool before cleaning.

Cooking Guide

Divider

- The divider does not completely isolate the heat transfer and food splatters between the two baskets during cooking. This is normal.

Overfilling

- If the basket is overfilled, food will cook unevenly.
- **CAUTION: Do not** pack in food. Heaping amounts of food may touch the heating coils and cause a fire hazard.

Using Oil

- Adding a small amount of oil to your food will make it crispier. Use no more than 30 mL / 2 US tbsp of oil.
- Oil sprays are excellent for applying small amounts of oil evenly to all food items.
- **Do not** use cooking sprays with propellants. Propellants may damage the basket's nonstick coating.

Food Tips

- You can air fry any frozen foods or goods that can be baked in an oven.
- To make cakes, hand pies, or any food with filling or batter, place food in a heat-safe container before placing in the basket.
- Air frying high-fat foods will cause fat to collect underneath the crisper plates. To avoid excess smoke while cooking, pour out fat drippings after cooking.
- Liquid-marinated foods create splatter and excess smoke. Pat these foods dry before air frying.

French Fries

- Add 8–15 mL / ½–1 US tbsp oil for crispiness.
- When making fries from raw potatoes, soak uncooked fries in water for 15 minutes to remove starch prior to frying. Pat dry with a towel before adding oil.
- Cut uncooked fries smaller for crispier results. Try cutting fries into 0.6- by 7.6-cm / ¼- by 3-inch strips.

Note: For more tips and recipes, check out the VeSync app and Quick Start Guide.

More Functions

Switching Temperature Units

- Press and hold temperature \wedge and \vee for 3 seconds.
- The air fryer will beep once, and the temperature unit will change from Celsius to Fahrenheit.
- Repeat to switch back to Celsius.

Turn Sound On/Off

- Press and hold temperature \wedge and time \wedge at the same time for 3 seconds until the air fryer beeps once.
- Repeat to turn the sound back on.

Pausing

- Tap $\blacktriangleright\parallel$ to pause cooking. The air fryer will stop heating, and $\blacktriangleright\parallel$ will blink until you tap $\blacktriangleright\parallel$ again to resume cooking.
- After 30 minutes of inactivity, the air fryer will turn off.
- This function allows you to pause cooking without removing the basket from the air fryer.

Cooking Functions' Settings

Using a cooking function is the easiest way to air fry. Cooking functions are programmed with an ideal time and temperature for cooking certain foods.

- To customise a function:
 - Choose a function and adjust the time and temperature.

Note: To rapidly increase or decrease time or temperature, press and hold the \wedge or \vee buttons.

- Press and hold the function's button until the air fryer beeps once.
- To reset a function:
 - Without making changes, press and hold the function's button and **GRANDZONE** at the same time for 3 seconds until the air fryer beeps once.
- To reset all functions:
 - Press and hold **ZONE 1** and **ZONE 2** at the same time for 3 seconds until the air fryer beeps once.

Automatically Resume Cooking

- If you pull out the basket, the air fryer will pause cooking automatically.
- When you return the basket, the air fryer will automatically resume cooking based on your previous settings.

Automatic Shutoff

- If the air fryer has no active functions, the air fryer will clear all settings and turn off after 20 minutes of inactivity.

CARE & MAINTENANCE

Note:

- **Always** clean the air fryer basket and crisper plates after every use.
- Lining the basket with foil (except the crisper plates) may make cleanup easier.

1. Turn off and unplug the air fryer. Allow it to cool completely before cleaning. Pull out the basket for faster cooling.
2. Wipe the outside of the air fryer with a moist cloth, if necessary.
3. The basket and crisper plates are dishwasher-safe. You can also wash them with hot, soapy water and a non-abrasive sponge. Soak if necessary.

Note:

- The basket and crisper plates have a nonstick coating. Avoid using metal utensils and abrasive cleaning materials.

4. For stubborn grease:
 - a. In a small bowl, mix 30 g / 2 US tbsp of baking soda and 15 mL / 1 US tbsp of water to form a spreadable paste.
 - b. Use a sponge to spread the paste on the basket and crisper plates and scrub. Let the basket and crisper plates sit for 15 minutes before rinsing.
 - c. Wash basket and crisper plates with soap and water before using.

5. Clean the inside of the air fryer with a slightly moist, non-abrasive sponge or cloth. **Do not** immerse in water. If needed, clean the heating coil to remove food debris. [Figure 8.1]

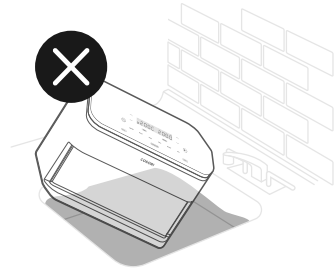

Figure 8.1

6. Dry before using.

Note: Make sure the heating coil is completely dry before turning on the air fryer.

ACCESSORIES

Additional and replacement accessories are available for your air fryer. For more information, contact **Customer Support** (see page 27).

TROUBLESHOOTING

Problem	Possible Solution
The air fryer will not turn on.	Make sure the air fryer is plugged in.
	Push the basket securely into the air fryer.
How do I pause one Zone when using both Zones?	To pause one Zone , first press the Zone button then press ► . To pause both Zones simply press the ► .
How do I stop one Zone when using both Zones?	To stop one Zone , Press and hold that zone's button for 3 seconds.
Is the basket safe to put on my worktop?	The basket will heat up during cooking. Use caution when handling, and place on heat resistant surfaces only.
Food is not completely cooked.	Place smaller batches of food items into the basket. If the basket is overstuffed, then foods will be undercooked.
	Increase cooking temperature or time.
Food is cooked unevenly.	Food that is stacked on top of each other or close to each other needs to be shaken or flipped during cooking.
Food is not crispy after air frying.	Spraying or brushing a small amount of oil on foods can increase crispiness (see Cooking Guide , page 19).
French fries are not cooked correctly.	See French Fries , page 19.
Basket will not slide into the air fryer securely.	Make sure the basket is not overfilled with food.
	Make sure the crisper plates are securely inside the basket.
White smoke or steam is coming out of the air fryer.	The air fryer may produce some white smoke or steam when you use it for the first time or during cooking. This is normal.
	Make sure the basket and the inside of the air fryer are cleaned properly and not greasy.
	Cooking greasy foods will cause oil to collect beneath the crisper plates. This oil will produce white smoke, and the basket may be hotter than usual. This is normal and should not affect cooking. Handle the basket with care.

TROUBLESHOOTING (CONT.)

Problem	Possible Solution
Dark smoke is coming out of the air fryer.	Immediately unplug your air fryer. Dark smoke means that food is burning or there is a circuit problem. Wait for smoke to clear before pulling the basket out. If the cause was not burnt food, contact Customer Support (see page 27).
The air fryer has a plastic smell.	Any air fryer may have a plastic smell from the manufacturing process. This is normal. Follow the instructions for a Test Run (page 12) to get rid of the plastic smell. If a plastic smell is still present, please contact Customer Support (see page 27).
Cooking time is longer when using Grandzone or Match cooking.	This is normal. Large quantities of food may take longer to cook.
How do I adjust the temperature or time while using a single zone?	Select the active Zone , then use the TEMP arrows to adjust the temperature TIME arrows to adjust the time.
Does the unit need to pre-heat?	The unit does not need to be pre-heated.
Can I cook different foods in each Zone and not worry about cross contamination?	Yes, both Zones are self-contained with separate heating elements and fans.

TROUBLESHOOTING (CONT.)

Problem	Possible Solution
Display shows Error Code "E1".	There is an open circuit in the upper temperature monitor of ZONE 1. Contact Customer Support (see page 27).
Display shows Error Code "E2".	There is a short circuit in the upper temperature monitor of ZONE 1. Contact Customer Support (see page 27).
Display shows Error Code "E21".	There is an open circuit in the lower temperature monitor of ZONE 1. Contact Customer Support (see page 27).
Display shows Error Code "E22".	There is a short circuit in the lower temperature monitor of ZONE 1. Contact Customer Support (see page 27).
Display shows Error Code "E3".	The air fryer's ZONE 1 overheat protection has activated. Turn off and unplug the air fryer and allow it to cool completely. If the display continues to show "E3", contact Customer Support (see page 27).
Display shows Error Code "E24".	There is an open circuit in the upper temperature monitor of ZONE 2. Contact Customer Support (see page 27).
Display shows Error Code "E25".	There is a short circuit in the upper temperature monitor of ZONE 2. Contact Customer Support (see page 27).
Display shows Error Code "E26".	There is an open circuit in the lower temperature monitor of ZONE 2. Contact Customer Support (see page 27).
Display shows Error Code "E27".	There is a short circuit in the lower temperature monitor of ZONE 2. Contact Customer Support (see page 27).
Display shows Error Code "E28".	The air fryer's ZONE 2 overheat protection has activated. Turn off and unplug the air fryer and allow it to cool completely. If the display continues to show "E28", contact Customer Support (see page 27).

If your problem is not listed, please contact **Customer Support** (see page 27).

DECLARATION OF CONFORMITY

Etekcitcity GmbH hereby declares that this product is in compliance with the essential requirements and other relevant provisions of Directive 2014/53/EU, UK Radio Equipment Regulations 2017 and all other applicable EU and UK directive requirements. The complete declaration of conformity can be found at: <https://cosori.com/euro/compliance>

LIMITED WARRANTY INFORMATION

Product Name	Dual Blaze TwinFry™ 10-Litre Air Fryer
Model	CAF-TF101S-AUK
<i>For your own reference, we strongly recommend that you record your order ID and date of purchase.</i>	
Date of Purchase	
Order ID	

TERMS & POLICY

Cosori Limited Product Warranty

Two (2) Year* Limited Consumer Product Warranty

VESYNC (SINGAPORE) PTE. LTD. warrants that the product shall be free from defects in material and workmanship for a period of **2 years from the date of original purchase** ("Limited Warranty Period"), provided the product was used in accordance with its use and care instructions (e.g., in the intended environment and under normal circumstances). ****This warranty does not limit your rights as may be mandated or granted by the applicable national or regional consumer protection laws in your region, in which cases the Limited Warranty Period is extended pursuant to the applicable requirements.***

Your Limited Warranty Benefits

During the Limited Warranty Period and subject to this limited Warranty Policy, VESYNC (SINGAPORE) PTE. LTD. will, in its sole and exclusive discretion, either (i) refund the purchase price if the purchase was made directly from the online Cosori store, (ii) repair any defects in material or workmanship, (iii) replace the product with another product of equal or greater value, or (iv) provide store credit in the amount of the purchase price.

Who is Covered?

This limited warranty extends only to the original consumer purchaser of the product and is not transferable to any subsequent owner of the product, regardless of whether the product transferred ownership during the specified term of the limited warranty. The original consumer purchaser must provide verification of the defect or malfunction and proof of the date of purchase to claim the Limited Warranty Benefits.

Be Aware of Unauthorized Dealers or Sellers

This limited warranty does not extend to products purchased from unauthorized dealers or sellers. Etekcity/VESYNC (SINGAPORE) PTE. LTD. purchased from authorized dealers or sellers that are subject to VESYNC (SINGAPORE) PTE. LTD.'s quality controls and have agreed to follow its quality controls. Please be aware, products purchased from an unauthorized website or dealer may be counterfeit, used, defective, or may not be designed for use in your country. You can protect yourself and your products by making sure you only purchase from VESYNC (SINGAPORE) PTE. LTD. or its authorized dealers.

If you have any questions about a specific seller, or if you think you may have purchased your product from an unauthorized seller, please contact our Customer Support Team.

What's Not Covered?

- Normal wear and tear, including normal wearing parts, such as dust bin, filter, roller brush, battery, and power cord, or carpet or floor damage due to misuse.
- If the proof-of-purchase has been altered in any way or is made illegible.
- If the model number, serial number or production date code on the product has been altered, removed or made illegible.
- If the product has been modified from its original condition.
- If the product has not been used in accordance with directions and instructions in the user manual.
- Damages caused by connecting peripherals, additional equipment or accessories other than those recommended in the user manual.
- Damages or defects caused by accident, abuse, misuse, or improper or inadequate maintenance.
- Damages or defects caused by service or repair of the product performed by an unauthorized service provider or by anyone other than VESYNC (SINGAPORE) PTE. LTD..
- Damages or defects occurring during commercial use, rental use, or any use for which the product is not intended.
- If the unit has been damaged, including but not limited to damage by animals, lightning, abnormal voltage, fire, natural disaster, transportation, dishwasher, or water (unless the user manual expressly states that the product is dishwasher-safe).
- Incidental and consequential damages.
- Damages or defects exceeding the cost of the product.

Claiming Your Limited Warranty Service in 5 Simple Steps:

1. Make sure your product is within the specified limited warranty period.
2. Make sure you have a copy of the invoice and order ID or proof-of-purchase.
3. Make sure you have your product. **DO NOT** dispose of your product before contacting us.
4. Contact our Customer Support Team.

5. Once our Customer Support Team has approved your request, please return the product with a copy of the invoice and order ID.

Sole and Exclusive Remedy

THE FOREGOING LIMITED WARRANTY CONSTITUTES VESYNC (SINGAPORE) PTE. LTD.'S EXCLUSIVE LIABILITY, AND YOUR SOLE AND EXCLUSIVE REMEDY, FOR ANY BREACH OF ANY WARRANTY OR OTHER NONCONFORMITY OF THE PRODUCT COVERED BY THIS LIMITED PRODUCT WARRANTY STATEMENT. THIS LIMITED WARRANTY IS EXCLUSIVE, AND IN LIEU OF ALL OTHER WARRANTIES. NO EMPLOYEE OF VESYNC (SINGAPORE) PTE. LTD. OR ANY OTHER PARTY IS AUTHORIZED TO MAKE ANY WARRANTY IN ADDITION TO THE LIMITED WARRANTY IN THIS LIMITED PRODUCT WARRANTY STATEMENT.

Disclaimer of Limited Warranties

TO THE FULLEST EXTENT PROVIDED BY APPLICABLE LAW, EXCEPT AS WARRANTED IN THIS LIMITED PRODUCT WARRANTY POLICY, VESYNC (SINGAPORE) PTE. LTD. PROVIDES THE PRODUCTS YOU PURCHASE FROM VESYNC (SINGAPORE) PTE. LTD. "AS IS" AND VESYNC (SINGAPORE) PTE. LTD. HEREBY DISCLAIMS ALL WARRANTIES OF ANY KIND, WHETHER EXPRESS OR IMPLIED, STATUTORY, OR OTHERWISE, INCLUDING BUT NOT LIMITED TO ANY WARRANTIES OF MERCHANTABILITY, NON-INFRINGEMENT, AND FITNESS FOR PARTICULAR PURPOSE.

Limitations of Liability

TO THE FULLEST EXTENT PROVIDED BY APPLICABLE LAW, IN NO EVENT WILL VESYNC (SINGAPORE) PTE. LTD., ITS AFFILIATES, OR THEIR LICENSORS, SERVICE PROVIDERS, EMPLOYEES, AGENTS, OFFICERS, OR DIRECTORS BE LIABLE FOR:

- (a) DAMAGES OF ANY KIND ARISING OUT OF OR IN CONNECTION WITH PRODUCTS PURCHASED FROM VESYNC (SINGAPORE) PTE. LTD. IN EXCESS OF THE PURCHASE PRICE PAID BY THE PURCHASER FOR SUCH PRODUCTS, OR
- (b) INDIRECT, SPECIAL, INCIDENTAL, CONSEQUENTIAL, OR PUNITIVE DAMAGES EVEN IF VESYNC (SINGAPORE) PTE. LTD. OR ONE OF ITS SUPPLIERS HAS BEEN ADVISED OF THE POSSIBILITY OR LIKELIHOOD OF SUCH DAMAGES.

AND REGARDLESS OF WHETHER CAUSED BY TORT (INCLUDING NEGLIGENCE), BREACH OF CONTRACT, OR OTHERWISE. OUR LIABILITY SHALL UNDER NO CIRCUMSTANCES EXCEED THE ACTUAL AMOUNT PAID BY YOU FOR THE DEFECTIVE PRODUCT, NOR SHALL WE UNDER ANY CIRCUMSTANCES BE LIABLE FOR ANY CONSEQUENTIAL, INCIDENTAL, SPECIAL OR PUNITIVE DAMAGES OR LOSSES, WHETHER DIRECT OR INDIRECT.

EXCEPT AS COVERED BY THIS LIMITED PRODUCT WARRANTY STATEMENT, VESYNC (SINGAPORE) PTE. LTD. SHALL NOT BE LIABLE FOR COSTS ASSOCIATED WITH THE REPLACEMENT OR REPAIR OF PRODUCTS

PURCHASED FROM IT, INCLUDING, BUT NOT LIMITED TO, LABOR, INSTALLATION, OR OTHER COSTS INCURRED BY THE USER AND, IN PARTICULAR, ANY COSTS RELATING TO THE REMOVAL OR REPLACEMENT OF ANY PRODUCT.

Other Rights You May Have

SOME JURISDICTIONS DO NOT ALLOW FOR: (1) EXCLUSION OF IMPLIED WARRANTIES; (2) LIMITATION ON THE DURATION OF IMPLIED WARRANTIES; AND/ OR (3) EXCLUSION OR LIMITATION OF INCIDENTAL OR CONSEQUENTIAL DAMAGES; SO THE DISCLAIMERS IN THIS POLICY MAY NOT APPLY TO YOU. IN THESE JURISDICTIONS YOU HAVE ONLY THE IMPLIED WARRANTIES THAT ARE EXPRESSLY REQUIRED TO BE PROVIDED IN ACCORDANCE WITH APPLICABLE LAW. THE LIMITATIONS OF WARRANTIES, LIABILITY, AND REMEDIES APPLY TO THE MAXIMUM EXTENT PERMITTED BY LAW.

ALTHOUGH THIS LIMITED WARRANTY GIVES YOU SPECIFIC LEGAL RIGHTS, YOU MAY HAVE OTHER RIGHTS IN YOUR JURISDICTION. THIS STATEMENT OF LIMITED WARRANTY IS SUBJECT TO APPLICABLE LAWS THAT APPLY TO YOU AND THE PRODUCT. PLEASE REVIEW THE LAWS IN YOUR JURISDICTION TO UNDERSTAND YOUR RIGHTS FULLY.

Changes to this policy

We may change the terms and availability of this limited warranty at our discretion, but any changes will not be retroactive.

This warranty is made by:

VESYNC (SINGAPORE) PTE. LTD.
6 Raffles Quay, #14-06, 048580 Singapore

CUSTOMER SUPPORT

If you have any questions or concerns about your new product, please contact our helpful Customer Support Team.

Email:

support.uk@cosori.com

**Please have your order invoice PDF or screenshot(s) ready before contacting Customer Support.*

Attributions

Google, Android, and Google Play are trademarks of Google LLC.

App Store® is a trademark of Apple Inc.

Wi-Fi® is a registered trademark of Wi-Fi Alliance®.

iOS is a registered trademark of Cisco Systems, Inc. and/or its affiliates in the United States and certain other countries.

The Bluetooth® word mark and logos are registered trademarks owned by Bluetooth SIG, Inc. and any use of such marks by Etekcitiy GmbH is under license. Other trademarks and trade names are those of their respective owners.

SHOW US WHAT YOU'RE MAKING

We hope this has been helpful to you. We can't wait to see your beautiful results, and we think you'll want to share glam shots! Our community awaits your uploads—just pick your platform of choice below. Snap, tag, and hashtag away, Cosori chef!

@cosori_uk



@cosori.uk



@Cosori UK



COSORI

Questions or Concerns?
support.uk@cosori.com

A1-24E24-UK